



Annual Report 2017



PRICOL LIMITED
Passion to Excel

CONTENTS

CORPORATE OVERVIEW

New Investments this Year.....	03
Some of our New Businesses.....	08
CSR Initiatives	11

MANAGEMENT REPORTS & FINANCIAL STATEMENTS

Director's Report & Management Analysis.....	15
Report on Corporate Governance.....	34
Independent Auditor's Report	46
Balance Sheet	52
Statement of Profit & Loss	53
Cash Flow Statement	54
Notes to Financial Statements.....	55
Consolidated Financial Statements.....	81

STAKEHOLDERS



CUSTOMERS



EMPLOYEES



SHAREHOLDERS



SUPPLIERS

Our logo represents the synergistic relationship between the four stakeholders working in a convergent manner in order to create value for each other.

CORPORATE VISION

We will strive to attain **leadership** and **excellence** in all the products and services that we provide, through **socially** and **environmentally** acceptable means.

CORPORATE MISSION

Be ***Dynamic***

Constantly innovate and find better ways to deliver value to our customers.

Constantly ***Evolve***

Improve in every sphere of our activity

Work ***Passionately***

To enhance value to our customers, employees, suppliers and shareholders.

Be ***Sustainable***

Care for the society and environment around us.

CORE VALUES

***P*ASSION**

Whatever we do, we do it from the bottom of our heart

***R*ESPECT**

We respect those who add value to our lives

***I*NTEGRITY**

We never compromise on our values

***C*OLLABORATION**

We believe in working towards a unified goal

***O*WNSHIP**

We are responsible for all our actions

***L*ISTEN**

We listen to both the spoken and unspoken before we act

Pricol Limited Commissioned a state-of-the-art Greenfield Manufacturing Plant in Pune

Pricol Limited recently inaugurated its high-efficiency plant built across 6.58 Acres in Phulgaon, Pune. The new facility incorporates Green concepts of Solar power and Variable Refrigerant Flow (VRF) air conditioning. Roof-top solar panels fulfill 40% of the daily power requirement. The production lines are designed on lean manufacturing principle with improved layout for streamlined material flow to ensure quality consistency and material efficiency.

The state-of-the-art manufacturing plant at Pune aims to generate an annual revenue of ₹ 220 Crore in the next 2 years, up from the current annual revenue of ₹ 120 Crore, thus contributing to Pricol's 2020 vision. New investments in Surface-Mount Technology (SMT)-Printed Circuit Boards (PCB) manufacturing lines will cater to the growing Electronic Cluster business not only in Two Wheeler but also in Commercial Vehicle, Off Road and Tractor segments. Investments in Electronics Manufacturing will also contribute to the growing Body Control Module and Telematics businesses. The plant also has New Technology Pump production lines catering to the domestic and export markets. With manufacturing operations in Indonesia, Brazil and India, the new plant in Pune will add impetus to the manufacturing operations of Pricol in the global market.



Die Casting Shop - Plant III

Investment in Die Casting shop at Plant III in Coimbatore, India. This shop is built over 35,000 square feet of area and will be fully operational by July 2017.



No Fault Forward Assembly lines for Driver Information System - Plant I



New assembly lines with No Fault Forwarding (NFF) principle ensuring higher quality focus through essential mistake proofing in every step of the process. Barcode traceability in each step of the process, from start to finish of the assembly line.

Driver Information System Assembly Line - Plant I



New assembly line with process interlock for Royal Enfield's Driver Information System which conforms to BS IV standards and includes advanced features like LCD Compass.

Mechanical Cluster Line – Plant II



Semi-Automatic assembly line with closed loop processes for assembling Honda Shine Cluster. This assembly line ensures defect free assembly with higher quality control.

JCB Live Link ECU – A Telematics Product Assembly Line – Plant II



An Electronic Control Unit (ECU) for JCB “Live Link”, is a Telematics product assembly line at Plant II. This Telematics ECU line is a state-of-the-art assembly line with Real Time GSM based product assembly and fully automatic inspection carried out through external software. This ensures zero defect during assembly and server based traceability from the field.

Chain Tensioner Assembly Line – Plant II



New assembly line built with advanced processes and quality controls through feedback control system for Honda. This assembly line provides an extra capacity of 50% when compared to the existing assembly line.

Surface Mounting Device (SMD Machines) - Plant V



Advanced automated SMD Mounters, Printers & Robotic Machines which are being used to place Surface Mount Devices (SMD) onto Printed Circuit Board (PCB) for Electronic Clusters. They are used for high speed, high precision placing of broad range of electronic components like capacitors, resistors, integrated circuits onto the PCBs.

TFR FLS Semi-Automatic Line - Plant V

New assembly line for TFR (Thick Film Resistor) type Fuel Level Sensor (FLS) with robotic soldering, multi process SPM (Special Purpose Machine) and automatic component pick and placers. Automated end of line inspection with dual fixturing for doubling the capacity of the existing assemble line.



Four Stroke Oil Pump Assembly Line – Plant V



New assembly line with semi-automatic and combined processes ensuring error free product assembly with high productivity. All the processes in this line are closed loop with feedback system and automated dynamic torque checking which ensures the Oil pump's 100% performance.

HERO - PASSION X-PRO



Customer : Hero Motocorp Ltd.
 Model : Passion X-Pro
 Market : India
 Product Details : Stepper Motor Driven Speedometer with LCD

BAJAJ - KTM

Customer : Bajaj Auto Ltd.
 Model : KTM - ABS
 Market : India
 Product Details : CAN Controlled LCD Instrument Cluster



JCB - BACKHOE

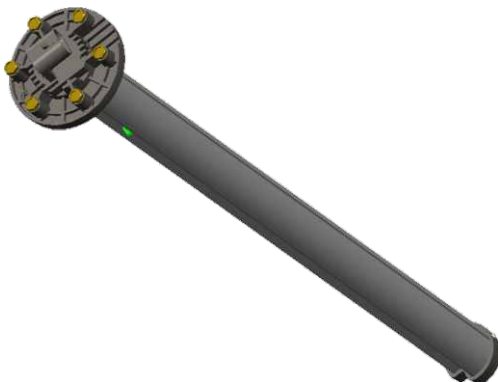

Customer : JCB India Ltd.
 Model : 3DX Backhoe
 Market : India
 Product Details : Reed Type Fuel Level Sensor

JCB - COMPACTOR



Customer : JCB Excavators Ltd., UK.
 Model : P461 Compactor
 Market : United Kingdom
 Product Details : Stepper Motor Driven Speedometer

HONDA - SHINE

Customer : Honda Motorcycle & Scooter India Ltd.
 Model : Shine
 Market : India
 Product Details : Stepper Motor Driven Speedometer



HONDA - SHINE

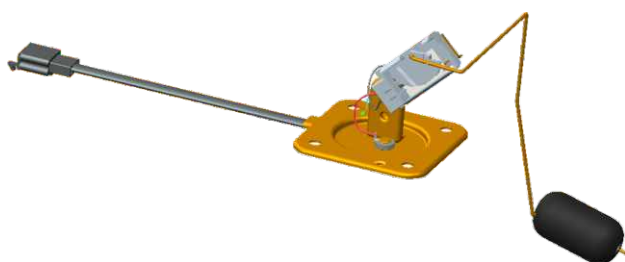

Customer : Honda Motorcycle & Scooter India Ltd.
 Model : Shine
 Market : India
 Product Details : TFR Type Fuel Level Sensor

HONDA - AVIATOR

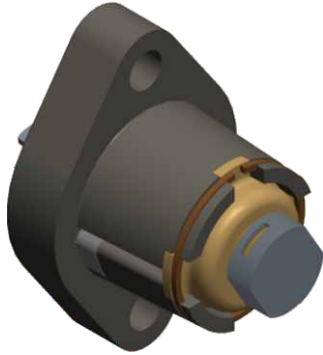

Customer : Honda Motorcycle & Scooter India Ltd.
Model : Aviator
Market : India
Product Details : Screw Type Chain Tensioner

AMBULANCE TELEMATICS



Ambulance Telematics:

Vehicle Tracking Solution delivered to Ziqitza Health Care Limited which provides ambulance services to the State Government of Maharashtra.



Health

Maternity ward at Primary Health Center :

A new maternity ward was constructed and latest medical equipment were provided to the Primary Health Center in Udumalaipettai, Tirupur. Around 8 villages surrounding this Primary Health Center will be benefited from this Maternity Ward.

Eye Camps :

21 Eye camps were conducted in Government schools in and around Coimbatore, India in which more 1300 children were benefitted. 4 Eye camps were conducted for the general public in and around Coimbatore in which nearly 1000 people were benefitted. Deserving people were are also supported with surgeries.



Medical Camp :

To increase health awareness in Rural and Tribal villages, a medical camp was conducted at Valavadi village, Udumalaipettai. Around 400 people from in and around the village benefitted from the program.

Medical Equipment for Government Hospital :

Latest medical equipment was provided to the Government Hospital in Pantnagar, Uttarakhand near Pricol Limited's Plant 6.

Physiotherapy Equipment :

Physiotherapy Equipment was provided to Rapid Action Force (RAF) in Vellore, Coimbatore.



Developing Government Schools

Computer Lab at Primary School:

Computer Lab facility was provided to Primary School at Valavadi, Udumalaipettai. 5 computers along with UPS were installed. The school was white washed and some basic maintenance work were also carried out.

Lab Facilities at High Schools:

The Government High School at Valavadi, Udumalaipettai was provided with Lab facilities for the subjects Physics, Chemistry, Botany and Zoology. These facilities have benefitted the 11th and 12th standard students of this school and the school has already started seeing good results.



Water Purifies & AMC:

Water Purifiers with UV and Ozone technology were distributed at 5 primary health centers at Tirupur & Coimbatore. The purifiers are provided with four years of free Annual Maintenance Contract.

Financial support:

Financial support was provided to organisations like Wildlife SOS, Siruthuli and Coimbatore City Police supporting their respective social actions.

Tree Park Development:

An existing Tree Park near Primary Health Center Valavadi, Udumalaipettai has been developed and maintained. The Tree Park, being in proximity to the Primary Health Center, will benefit the visitors and patients of the Health Center.



Board of Directors

Mr. Vijay Mohan, Chairman	(DIN: 00001843)
Mrs. Vanitha Mohan, Vice Chairman	(DIN: 00002168)
Mr. Vikram Mohan, Managing Director	(DIN: 00089968)
Mr. C.R. Swaminathan	(DIN: 00002169)
Mr. K. Murali Mohan	(DIN: 00626361)
Mr. Suresh Jagannathan	(DIN: 00011326)
Mr. R. Vidhya Shankar	(DIN: 00002498)
Mr. G. Soundararajan	(DIN: 00037995)
Mrs. Sriya Chari	(DIN: 07383240)

Chief Financial Officer

Mr. S. Shrinivasan

Company Secretary

Mr. T.G. Thamizhanban

Auditors

M/s. Haribhakti & Co. LLP
 Chartered Accountants,
 "Shree Shanmugappriya", 2nd Floor,
 454, Ponnaiyan Street, Crosscut Road,
 Gandhipuram, Coimbatore - 641 012, India

Bankers

State Bank of India
 HDFC Bank Limited
 Bank of Bahrain and Kuwait B.S.C.
 Axis Bank Limited
 ICICI Bank Limited
 The Federal Bank Limited

Registered Office

109, Race Course,
Coimbatore - 641 018, India
Phone : +91 422 4336000 Fax : +91 422 4336299
E-mail : cs@pricol.co.in Website: www.pricol.com
CIN : L34200TZ2011PLC022194

Factories

PLANT I

132, Mettupalayam Road,
Perianaickenpalayam,
Coimbatore - 641 020, India.

PLANT II

Plot No.34 & 35, Sector 4,
IMT Manesar,
Gurugram - 122 050, India.

PLANT III

4/558, Mettupalayam Road,
Chinnamathampalayam,
Bilichi Village,
Press Colony Post,
Coimbatore - 641 019, India.

PLANT V

Gat No.180-187,
Global Rasoni Industrial Park,
Alandi-Markal Road,
Phulgaon, Tal-Haveli,
Pune - 412216, India.

PLANT VI

Plot No.11, Sector 10,
Integrated Industrial Estate,
Pantnagar, SIDCUL,
Rudrapur - 263 153, India.

PLANT VII

Plot No.45, Sector 11,
Integrated Industrial Estate,
Pantnagar, SIDCUL,
Rudrapur - 263 153, India.

DIRECTORS' REPORT & MANAGEMENT ANALYSIS

Your Directors have pleasure in presenting the Sixth Annual Report and audited accounts for the financial year ended 31st March, 2017.

FINANCIAL RESULTS

The summarised financial results are: ₹ Million

	2016-17	2015-16
Net Sales & Services		
- Domestic	11,305.666	11,002.971
- Export	840.961	1,017.929
Other Operating Revenue	501.968	460.611
Other Income	35.671	99.306
Total Revenue	12,684.266	12,580.817
Profit from Operations before Finance Cost, Depreciation and Amortisation Expense & Exceptional Items	1,362.583	1,235.792
Less : Finance Costs	78.270	97.671
: Depreciation	375.859	368.048
Profit from Operations before Amortisation Expense, Exceptional Items & Tax	908.454	770.073
Less : Amortisation Expense	284.074	60.169
Add : Exceptional Items	5.337	(17.662)
Profit Before Tax	629.717	692.242
Less : Tax Expense		
Current Tax	137.000	166.840
Deferred Tax	172.000	(24.000)
MAT Credit	(137.000)	—
For earlier years	—	28.003
Profit After Tax	457.717	521.399

Note: For 2015-16, merged entity figures are given for comparative purposes.

DIVIDEND

Your Directors recommend a dividend of ₹ 1/- per share of ₹ 1/- face value for the year ended 31st March 2017 and the total dividend payout is ₹ 114.095 Million including dividend distribution tax.

AUTO INDUSTRY

During the year, the Auto Industry's domestic market grew by 6.81% and exports decreased by 4.50%. The overall growth was 5.09% as against 3.49% in the previous financial year.

The performance as per Society of Indian Automobile Manufacturers (SIAM) is :

Category	Vehicles Sold		Growth
	2016-17 In numbers	2015-16	2016-17 %
Passenger Car / Utility Vehicle	3,621,487	3,263,044	10.99
Vans	184,070	179,217	2.71
Medium & Heavy Commercial Vehicle	346,248	337,594	2.56
Light Commercial Vehicle	476,255	451,234	5.55
Motor Cycles / Scooters / Mopeds	19,928,784	18,938,727	5.23
Three Wheelers	783,552	942,649	(16.88)
Total	25,340,396	24,112,465	5.09

OPERATIONS

The segments in the domestic market our Company primarily caters to are Two wheelers, Commercial Vehicles, Tractors and Off-road vehicles.

Consequent to market share reduction for some of our key domestic customers, our domestic sales grew marginally. Further due to reduction in our export sales, our overall revenue growth was only 0.82%.

The profit from operations before Amortisation Expense, Exceptional Items & Tax increased from ₹ 770.073 Million to ₹ 908.454 Million increase of 17.97 %, due to several operational improvements, cost reduction measures and reduction in finance cost.

Due to amalgamation, the company purchased the assets of the erstwhile Pricol Limited (transferor company) at the respective fair values, which lead to higher depreciation & amortisation expense for the year, resultant in decrease of Profit before tax to ₹ 629.717 Million from ₹ 692.242 Million.

For the ensuing year 2017-18, the Company's business is expected to grow higher than the market, mainly due to new business generated.

DIRECTORS' REPORT & MANAGEMENT ANALYSIS (Contd.,)

SUBSIDIARY COMPANIES

PT Pricol Surya Indonesia

The Company is supplying Instrument Clusters to the Two Wheeler manufacturers in Indonesia & Thailand.

In the financial year 2016-17, the company has achieved a Sales of Indonesian Rupiah 186,339 Million (₹ 922.378 Million) as against the previous year sales of Indonesian Rupiah 172,406 Million (₹ 848.236 Million) an increase of 8.08% in Indonesian Rupiah & 8.74% in INR terms. The difference in % is on account of exchange fluctuations.

The increase in sales is mainly on account of growth in the model that we are present in the Indonesian & Thailand markets. The cost control measures initiated by the Company has paid off well and resulted in turning around. The Company has achieved a Profit before Tax of Indonesian Rupiah 1,986 Million (₹ 9.829 Million) as against the loss of Indonesian Rupiah 5,679 Million (₹ 27.941 Million) of previous year.

Pricol Asia Pte Limited, Singapore

This purchasing arm of our Company mainly assists in global procurement of raw materials and components to supply our Company and associate companies.

In the financial year 2016-17, the Company achieved sales of USD 22.877 Million (₹ 1,500.798 Million) as against the previous year sales of USD 18.844 Million (₹ 1,236.453 Million).

The company made a Profit after Tax of USD 762,345 (₹ 50.011 Million) during the year 2016-17 as against USD 350,289 (₹ 21.808 Million) in 2015-16.

Pricol Espana Sociedad Limitada, Spain

It is an investment arm of Pricol to acquire companies in Europe and South America. During the financial year, the company has incurred a loss of EURO 0.120 Million (₹ 8.665 Million).

Pricol do Brasil Componentes Automotivos Ltda, Brazil

Pricol do Brasil Componentes Automotivos Ltda (PdB) manufactures and sells Pumps & Mechanical products to wide range of Domestic and International customers such as Volkswagen, Fiat, Fiat Powertrain, General Motors, Mack Trucks etc. PdB has a strong backward integrated facility with diverse manufacturing capabilities (Die Casting,

Machining and Assembly) and extensive Testing and Validation facilities to provide end to end solution and add value to the Customer.

R & D capabilities are another strong area of PdB and several new programs are on the advanced stage of development, such as :- Electric Coolant Pump, Electric Vacuum Pump, Electric Coolant Valve, Variable Flow Oil Pump, Variable Flow Water Pump, Solenoid Valve and Electric Oil Pump.

The Brazilian economy that has started declining couple of years back continued through 2016-17. During the year 2016-17, the economy has reduced by 3.6% & the Automotive market ended up with 20.20% reduction. During the year, PdB has increased its market share with key customers and thereby contained the reduction to 8.86%. In the current year, PdB has worked on to reduce and contain the expenses, production & labour costs through organisational restructuring.

Latest economic indicators show a slow recovery in Brazil for 2017. The stabilisation of Brazilian economy and solution of political matters will also help PdB reversing current financial results situation. The company was awarded with a contract to supply water pump to General Motor's new engine – The CSS project – which will be put in place at the end of 2019 and will represent an additional business of BRL 70 Million (₹ 1,450 Million) per year.

In the financial year 2016-17, PdB has achieved a sales of BRL 62.940 Million (₹ 1,233.804 Million) as against the previous year sales of BRL 69.060 Million (₹ 1,303.135 Million). PdB incurred a loss of BRL 22.224 Million (₹ 435.654 Million) during the year 2016-17 as against BRL 24.362 Million (₹ 459.682 Million) in 2015-16.

The Company is continuously working on improving the sales of both domestic and export.

AMALGAMATION

Amalgamation of Pricol Limited, listed entity (Pricol) with Pricol Pune Limited, wholly owned subsidiary of Pricol Limited, unlisted entity (Pricol Pune) pursuant to the Order dated 6th October 2016 of Hon'ble High Court, Madras, was made effective from 1st November 2016. Upon amalgamation, Pricol ceased to exist. Subsequent to the amalgamation the name of 'Pricol Pune Limited' changed to 'Pricol Limited' with effect from 18th November 2016.

By integrating the related auto component businesses of Pricol and Pricol Pune, the Company would be in a position to offer a wider portfolio of products and services to its

DIRECTORS' REPORT & MANAGEMENT ANALYSIS (Contd.,)

customers. The amalgamation would provide a high level of synergistic integration of operations, better operational management and provide value addition to existing and future orders of both the companies by integrating the respective technical, financial and other expertise and resources.

As part of the Amalgamation, all assets (including intangible assets not recorded by Pricol) and liabilities of Pricol as on the Appointed Date (1st April 2015) stand transferred to and vested with Pricol Pune. By amalgamation of Pricol into Pricol Pune, the combined entity would be able to reflect the true networth in the financial statements (as all assets, tangible and intangible, including those not recorded in the books of Pricol would be recorded in the books of Pricol Pune at their respective fair values). This would enable greater realisation of potential of the businesses of both the companies and result in enhanced value creation for the Company, shareholders, lenders and employees.

SHARES & LISTING

As consideration of amalgamation, on 7th December 2016, Company issued 94,796,721 new shares of face value ₹ 1 each (in ratio of 1:1) to shareholders of erstwhile Pricol Limited as on record date (6th December 2016). New shares issued were not additional shares. The shares (ISIN : INE605A01026) of erstwhile Pricol were debited and new shares (ISIN : INE726V01018) were issued to the shareholders. Pursuant to amalgamation, equity shares of Pricol Pune held by Pricol were cancelled. The shareholding pattern of the company stands as a mirror image of erstwhile Pricol's shareholding pattern.

On 9th December 2016, the said shares were credited to the demat account of shareholders holding shares in demat form and on 14th December 2016, physical share certificates were despatched to the shareholders holding shares in physical form.

Company obtained necessary approvals from SEBI & Stock Exchanges (BSE & NSE) and the new shares were listed & started trading in stock exchanges from 10th February 2017.

OUTLOOK, OPPORTUNITIES, CHALLENGES, RISKS & CONCERNS

The Indian automotive industry that has recorded double digit growth in first two quarters of 2016-17 has slumped to single digit in second half due to demonetisation of higher

denomination currencies. The overall growth of automotive sector for 2016-17 is 5.09% compared to 2015-16. The two wheeler segment grew at 5.23% & M&HCV segment registered a growth of 2.56%. These are the two segment primarily serviced by Pricol. As against the said market growth, Pricol had a revenue growth of ₹ 12,684 Million representing 0.82% over last year.

Though the effect of demonetisation has been partially reversed in Q4 of 2016-17, full recovery is expected in Q1 2017-18. The auto industry is looking to grow in 2017-18. According to SIAM reports, the expected growth of two wheeler and commercial vehicle segments are 9% & 4%. The outlook for H1 of 2017-18 is cautious growth, with BS4 change over impact in Q1, anticipated GST implementation in Q2.

Pricol is expected to outgrow the auto industry, primarily with improved penetration in electronic cluster business, improved market shares in pumps and mechanical products. We have a steady new product pipeline, including telematics and sensors domain.

RISK MANAGEMENT

The Company has adopted a Risk Management Policy, for identifying and managing risk, at the strategic, operational and tactical level. The Risk Management policy has been placed on the website of the Company and the web link there to is <http://www.pricol.com/Risk-Management-Policy.pdf>. Our risk management practices are designed to be responsive to the ever changing Industry dynamics.

At present the Company has not identified any element of risk which may threaten the existence of the Company.

INTERNAL CONTROL SYSTEMS AND THEIR ADEQUACY

The Company's internal control systems have been strengthened taking into account the nature of business and size of operations to provide for:

- Reliability and integrity of financial and operational information;
- Effectiveness and efficiency of operations and assets;
- Compliance with applicable statutes, policies, listing requirements and management policies and procedures.

DIRECTORS' REPORT & MANAGEMENT ANALYSIS (Contd.,)

The Company, through its own Corporate Internal Audit Department, carries out periodic audits at all locations and all functions and brings out any deviation to internal control procedures. The observations arising from audit are periodically reviewed and compliance ensured. The summary of the Internal Audit observations is submitted to the Audit Committee. The Audit Committee at its meetings regularly reviews the financial, operating, internal audit & compliance reports to improve performance. The heads of various monitoring / operating cells are present for the Audit Committee meetings to answer queries from the Audit Committee.

FINANCE

During the year the Company has not accepted / renewed any fixed deposit from public. The total deposits remained unpaid or unclaimed as at 31st March, 2017 is Nil. There is no default in repayment of deposits or payment of interest thereon during the year.

The Company undertook several steps to keep a control over borrowings and cost of borrowings.

ICRA has reaffirmed the credit rating of "A-" for Long term fund based facilities and "A2+" for short term fund based & non fund based facilities.

The particulars of Loans, Guarantees and Investments made by the Company under Section 186 of the Companies Act, 2013 are given in Note No. 2.55 to the Standalone Financial Statements.

RELATED PARTY TRANSACTIONS

All related party transactions that were entered into during the financial year were on arm's length basis and were in the ordinary course of the business. During the year, there were no materially significant related party transactions made by the Company with Promoters, Key Managerial Personnel or other designated persons which may have potential conflict with the interest of the Company at large.

SIGNIFICANT AND MATERIAL ORDERS PASSED BY THE REGULATORS OR COURTS OR TRIBUNALS

There are no significant and material orders passed by the Regulators / Courts / Tribunals which would impact the going concern status and the Company's operations in future.

DIRECTORS

As per the provisions of Section 149 of the Companies Act, 2013, Regulation 25 of the SEBI (Listing Obligations and

Disclosure Requirements) Regulations, 2015 and the Company's Directors retirement policy at the age of 70, the Members of the erstwhile Pricol Limited, appointed the independent directors as mentioned below:

Name of Independent Director	Period of Appointment
Mr. C. R. Swaminathan	Upto 28th February 2018
Mr. K. Murali Mohan	Upto 31st March 2018
Mr. Suresh Jagannathan	Upto 31st July 2019
Mr. R. Vidhya Shankar	Upto 31st July 2019
Mr. G. Soundararajan	Upto 31st July 2019
Mrs. Sriya Chari	Upto 26th May 2021

All Independent Directors have given declarations that they meet the criteria of independence as provided in Section 149(6) of the Companies Act, 2013.

During the year Mr. S.A.Gopalakrishnan and Mr. N.Subramanian resigned from the Board with effect from 1st November 2016. The Board appreciated the valuable services rendered by them during their tenure of office as Directors of the Company.

Mr. Vikram Mohan, a Non- Independent Director retires by rotation at the ensuing Annual General Meeting and is eligible for re- appointment.

EVALUATION BY THE BOARD

The Board has made a formal annual evaluation of its own performance, Committees of the Board, Independent Directors and Individual Directors of the Company.

The Board's performance was evaluated based on the criteria like Structure, Governance, Dynamics & Functioning, Approval & Review of Operations, Financials, Internal Controls etc.

The performance of the Independent Directors as well as Individual Directors including the Chairman of the Board were evaluated based on the evaluation criteria laid down under the Nomination and Remuneration Policy and the Code of Conduct as laid down by the Board.

The Committees of the Board were evaluated individually based on the terms of reference specified by the Board to the said Committee. The Board of Directors were satisfied with the evaluation process which ensured that the

DIRECTORS' REPORT & MANAGEMENT ANALYSIS (Contd.,)

performance of the Board, its Committees, Independent Directors and Individual Directors adhered to their applicable criteria.

KEY MANAGERIAL PERSONNEL

The Key Managerial Personnel of the Company as stipulated under Companies Act, 2013 are Mr. Vikram Mohan, Managing Director, Mr. S. Shrinivasan, Chief Financial Officer & Mr. T. G. Thamizhanban, Company Secretary.

STATUTORY AUDITORS

M/s. Haribhakti & Co. LLP the Statutory Auditors of the Company was appointed as Statutory Auditors of the Company, for a period of 4 consecutive years, to hold office from the conclusion of the 5th AGM held in the year 2016 to the conclusion of the fourth consecutive AGM to be held in the year 2020 (subject to ratification of the appointment by the members at every AGM).

M/s. Haribhakti & Co. LLP are eligible for ratification of appointment and have confirmed that their appointment, if approved, will be in compliance with Section 141 of the Companies Act, 2013.

Your Board recommends the ratification of appointment of M/s. Haribhakti & Co. LLP, as Statutory Auditors of the Company, to hold office from the conclusion of this AGM to the conclusion of the next AGM.

COST AUDITORS

The Board of Directors at its meeting held on 30th May 2017 appointed M/s. STR & Associates, Cost Accountants, as the Cost Auditors for conducting the Cost Audit for the financial year 2017-18. A resolution seeking members' ratification of the remuneration payable to Cost Auditor is included in the AGM notice dated 30th May 2017. The Cost Audit Report will be filed within the stipulated period.

SECRETARIAL AUDIT

The Company had appointed M/s. P. Eswaramoorthy and Company, Company Secretaries to undertake the Secretarial Audit of the Company for the financial year 2017-18. The Secretarial Audit Report is annexed herewith as "Annexure A".

CSR INITIATIVES

Pricol's Corporate Social Responsibility (CSR) activities reflect its philosophy of enhancing value to the society and the environment around us. The contribution in this regard

has been made to the registered trust which is undertaking these schemes in addition to the CSR activities directly undertaken by the Company. The Annual Report on CSR activities is annexed herewith as "Annexure B".

CONSERVATION OF ENERGY, TECHNOLOGY ABSORPTION AND FOREIGN EXCHANGE EARNINGS AND OUTGO

The information on conservation of energy, technology absorption and foreign exchange earnings and outgo stipulated under Section 134(3)(m) of the Companies Act, 2013 read with Rule 8 (3) of the Companies (Accounts) Rules, 2014 is annexed herewith as "Annexure C".

EXTRACT OF THE ANNUAL RETURN

The extract of the Annual Return in Form No. MGT-9 is annexed herewith as "Annexure D".

DEVELOPMENT IN HUMAN RESOURCES / INDUSTRIAL RELATIONS

Management and Union Representatives meeting is being conducted every month and the issues raised in the meetings are redressed immediately. Operators' Monthly Goodwill meeting is also being conducted every month and the shop floor issues for their day-to-day production are redressed immediately. Periodical review of the above issues are being carried out to ensure its completion. Periodical interactions with the union office bearers and the line operators have improved the conducive Industrial Relations. The number of people employed as on 31st March 2017 is 4,809.

DISCLOSURE UNDER THE SEXUAL HARASSMENT OF WOMEN AT WORKPLACE (PREVENTION, PROHIBITION AND REDRESSAL) ACT, 2013

The Company has in place an Anti Sexual Harassment Policy in line with the requirements of The Sexual Harassment of Women at the Workplace (Prevention, Prohibition & Redressal) Act, 2013. Internal Complaints Committee (ICC) has been set up to redress complaints received regarding sexual harassment. All employees (permanent, contractual, temporary and trainees) are covered under this policy. The Company has not received any sexual harassment complaint during the year 2016-17.

PARTICULARS OF EMPLOYEES

The information required pursuant to Section 197 read with Rule 5 of the Companies (Appointment and Remuneration of Managerial Personnel) Rules, 2014 in respect of

DIRECTORS' REPORT & MANAGEMENT ANALYSIS (Contd.,)

employees of the Company is annexed herewith as “Annexure E”.

DIRECTORS RESPONSIBILITY STATEMENT

In accordance with the provisions of Section 134(3)(c) of the Companies Act, 2013, the Directors would like to state that:

- a) in the preparation of annual accounts for the financial year ended 31st March 2017, the applicable accounting standards have been followed;
- b) they had selected such accounting policies and applied them consistently and made judgements and estimates that were reasonable and prudent so as to give a true and fair view of the state of affairs of the Company at the end of the financial year and of the profit and loss of the Company for the year under review;
- c) they had taken proper and sufficient care for the maintenance of adequate accounting records in accordance with the provisions of the Companies Act, 2013 for safeguarding the assets of the Company and for preventing and detecting fraud and other irregularities;
- d) they had prepared the annual accounts for the financial year ended 31st March 2017, on a going concern basis;
- e) they had laid down internal financial controls to be followed by the Company and such internal financial controls are adequate and were operating effectively and
- f) they had devised proper systems to ensure compliance with the provisions of all applicable laws and such systems were adequate and operating effectively.

CORPORATE GOVERNANCE

Your company reaffirms its commitment to good corporate governance practices. The company complies with corporate governance requirements specified in regulation 17 to 27 and clauses (b) to (i) of sub-regulation (2) of regulation 46 of the SEBI (Listing Obligations and Disclosure Requirements) Regulations, 2015.

Pursuant to Schedule V of SEBI (Listing Obligations and Disclosure Requirements) Regulations, 2015 the Report on Corporate Governance which forms a part of this Report, has been annexed herewith as “Annexure F”.

The Managing Director and Chief Financial Officer have certified to the Board with regard to the financial statements and other matters as required under Regulation 17 (8) of the SEBI (Listing Obligations and Disclosure Requirements) Regulations, 2015.

Practicing Company Secretary's Certificate regarding compliance of conditions of Corporate Governance, is made a part of this Directors' Report. All the board members and senior management personnel have affirmed compliance with the code of conduct for the year 2016-17.

CAUTIONARY STATEMENT

Management Discussion and Analysis forming part of this Report is in compliance with SEBI (Listing Obligations and Disclosure Requirements) Regulations, 2015 and such statements may be “forward-looking” within the meaning of applicable securities laws and regulations. Actual results could differ materially from those expressed or implied. Important factors that could make a difference to the Company's operations include economic conditions affecting demand / supply and price conditions in the domestic and overseas markets in which the Company operates, changes in the Government regulations, tax laws and other statutes and other incidental factors.

ACKNOWLEDGEMENTS

The Board takes this opportunity to place on record its appreciation to Customers, Distributors, Dealers, Suppliers, Shareholders, Bankers and Government authorities for their continued support and co-operation during the year under review. The Directors also wish to place on record their appreciation to the employees at all levels for their continued co-operation and commitment.

Coimbatore
30th May, 2017

For and on behalf of the Board
Vijay Mohan
Chairman
(DIN: 00001843)

★★★★★

ANNEXURE “A” TO DIRECTOR'S REPORT

Form No. MR - 3

SECRETARIAL AUDIT REPORT

FOR THE FINANCIAL YEAR ENDED 31st MARCH, 2017

[Pursuant to Section 204(1) of the Companies Act, 2013 and rule No.9 of the Companies (Appointment and Remuneration of Managerial Personnel) Rules, 2014]

To,

The Members,

Pricol Limited (Formerly Pricol Pune Limited)

[CIN: L34200TZ2011PLC022194]

109, Race Course, Coimbatore – 641 018.

I have conducted the secretarial audit of the compliance of applicable statutory provisions and the adherence to good corporate practices by **Pricol Limited, (formerly Pricol Pune Limited)** (hereinafter called the Company). Secretarial Audit was conducted in a manner that provided me a reasonable basis for evaluating the corporate conducts/statutory compliances and expressing my opinion thereon.

Based on my verification of the Company's books, papers, minute books, forms and returns filed and other records maintained by the Company and also the information provided by the Company, its officers, agents and authorized representatives during the conduct of secretarial audit, I hereby report that in my opinion, the Company has, during the audit period covering the financial year ended 31st March, 2017, complied with the statutory provisions listed hereunder and also that the Company has proper Board-processes and compliance-mechanism in place to the extent, in the manner and subject to the reporting made hereinafter.

I have examined the books, papers, minutes' books, forms and returns filed and other records maintained by the Company for the financial year ended 31st March, 2017 according to the provisions of :

- i) The Companies Act, 2013 (the Act) and the rules made thereunder and the applicable provisions of the Companies Act, 1956;
- ii) The Securities Contracts (Regulation) Act, 1956 ('SCRA') and the rules made thereunder;
- iii) The Depositories Act, 1996 and the Regulations and Bye-laws framed thereunder;
- iv) Foreign Exchange Management Act, 1999 and the rules and regulations made thereunder to the extent of Foreign Direct Investment, Overseas Direct Investment and External Commercial Borrowings;

- v) The following Regulations and Guidelines prescribed under the Securities and Exchange Board of India Act, 1992 ('SEBI Act'):-
 - a. The Securities and Exchange Board of India (Substantial Acquisition of Shares and Takeovers) Regulations, 2011;
 - b. The Securities and Exchange Board of India (Prohibition of Insider Trading) Regulations, 2015;
 - c. The Securities and Exchange Board of India (Issue of Capital and Disclosure Requirements) Regulations, 2009
 - d. The Securities and Exchange Board of India (Share Based Employee Benefits) Regulations, 2014 [Not applicable as the Company does not have any Scheme for share based employee benefits during the financial year under review];
 - e. The Securities and Exchange Board of India (Issue and Listing of Debt Securities) Regulations, 2008 [Not applicable as the Company has not issued and listed any debt securities during the financial year under review];
 - f. The Securities and Exchange Board of India (Registrars to an Issue and Share Transfer Agents) Regulations, 1993, regarding the Companies Act and dealing with client [Not applicable as the Company is not registered as Registrar to an Issue and Share Transfer Agent during the financial year under review];
 - g. The Securities and Exchange Board of India (Delisting of Equity Shares) Regulations, 2009 [Not applicable as the equity shares of the Company have not been delisted during the financial year under review];
 - h. The Securities and Exchange Board of India (Buyback of Securities) Regulations, 1998 [Not applicable as the Company has not bought back / proposed to buy back any of its securities during the financial year under review] and
 - i. The Securities and Exchange Board of India (Listing Obligations and Disclosure Requirements) Regulations, 2015.

I have relied on the representation made by the Company and its officers, relating to systems and mechanisms framed by the Company, for ensuring compliance with the other Acts, Laws and Regulations, as applicable to the Company.

I have also examined compliance with the applicable clauses of the following:

ANNEXURE “A” TO DIRECTOR'S REPORT (Contd.,)

- i) Secretarial Standards issued by The Institute of Company Secretaries of India.
- ii) The Listing Agreements entered into by the Company with BSE Limited and National Stock Exchange of India Limited.

During the period under review, the Company has complied with the provisions of the Act, Rules, Regulations, Guidelines, Standards, etc., mentioned above.

I further report that the Board of Directors of the Company is duly constituted with proper balance of Executive Directors, Non-Executive Directors and Independent Directors. The changes in the composition of the Board of Directors that took place during the period under review were carried out in compliance with the provisions of the Act.

Adequate notice is given to all Directors to schedule the Board Meetings, agenda and detailed notes on agenda were sent at least seven days in advance and a system exists for seeking and obtaining further information and clarifications on the agenda items before the meeting and for meaningful participation at the meeting.

I am informed that there were no dissenting members, on any of the matters, discussed at the Board Meetings during the financial year under review, whose views were required to be captured and recorded as part of the minutes.

I further report that based on the information provided by the Company, its officers and authorized representatives during the conduct of the audit and on the review of the quarterly compliance reports submitted by the respective department heads and the Company Secretary which is taken on record by the Board of Directors at their meeting(s), I am of the opinion that there are adequate systems and processes in place in the Company which is commensurate with the size and operations of the Company to monitor and ensure compliance with applicable laws, rules, regulations and guidelines.

I further report that the following specific events / actions having a major bearing on the Company's affairs took place during the audit period:

- a) Sale of 100% stake in Integral Investments Limited, a Wholly Owned Subsidiary Company.
- b) Hon'ble High Court of Madras sanctioned the Scheme of Amalgamation of Pricol Limited with Pricol Pune Limited vide its order dated 6th October, 2016 and

the amalgamation had come into effect from 1st November, 2016 with the Appointed Date as 1st April, 2015. Consequently, Pricol Limited stands dissolved without winding-up.

- c) The name of the Company had been changed from “Pricol Pune Limited” to “Pricol Limited” with effect from 18th November, 2016, pursuant to the order received from - Hon'ble High Court of Madras approving the Scheme of Amalgamation of Pricol Limited with Pricol Pune Limited and in compliance with the provisions of the Companies Act, 2013.
- d) The equity shares of Pricol Limited were suspended from trading on BSE Limited and National Stock Exchange Limited, with effect from 5th December, 2016, pursuant to the Scheme of Amalgamation of Pricol Limited and Pricol Pune Limited.
- e) The Committee of the Board of Directors of the Company at their meeting held on 7th December, 2016 had allotted equity shares to the shareholders of the erstwhile Pricol Limited, whose name appear in the Register of Members on the Record Date, 6th December, 2016 in the following ratio pursuant to the Scheme of Amalgamation of Pricol Limited and Pricol Pune Limited.
 “1 (One) fully paid up equity share of ₹ 1/- (One) each of Pricol Limited (formerly known as Pricol Pune Limited) for every 1 (One) fully paid equity share of ₹ 1/- (One) each held by such shareholder in erstwhile Pricol Limited.”
- f) The equity shares of Pricol Limited (formerly known as Pricol Pune Limited) had been listed and admitted to dealings on BSE Limited and National Stock Exchange Limited with effect from 10th February, 2017.

The members are requested to read this report along with my letter of even date annexed to this report.

P. ESWARAMOORTHY AND COMPANY

Company Secretaries

CS P. Eswaramoorthy

Proprietor

Coimbatore

30th May, 2017

FCS No. : 6510

CP No. : 7069

★★★★★

ANNEXURE TO SECRETARIAL AUDIT REPORT OF EVEN DATE

To

The Members,
Pricol Limited (Formerly Pricol Pune Limited)
 [CIN : L34200TZ2011PLC022194]
 109, Race Course,
 Coimbatore – 641 018.

My Secretarial Audit Report of even date is to be read along with this letter.

- Maintenance of secretarial records, devising proper systems to ensure compliance with the provisions of all applicable laws and regulations and ensuring that the systems are adequate and operate effectively, are the responsibilities of the management of the Company. My responsibility is to express an opinion on these secretarial records, systems, standards and procedures, based on audit.
- I have followed the audit practices and processes as were appropriate to obtain reasonable assurance about the correctness of the contents of the secretarial records. The verification was done on test basis to ensure that the correct facts are reflected in the secretarial records. I believe that the processes and practices, I followed provide a reasonable basis for my opinion.
- I have not verified the correctness and appropriateness of financial records and books of accounts of the Company.
- Wherever required, I have obtained the management's representation about the compliance of laws, rules and regulations and happening of events etc.
- The compliance of the provisions of Corporate and other applicable laws, rules, regulations, standards is the responsibility of management. My examination was limited to the verification of procedures on a test basis.
- The Secretarial Audit Report is neither an assurance as to the future viability of the Company nor of the efficacy or effectiveness with which the management has conducted the affairs of the Company.

P. ESWARAMOORTHY AND COMPANY

Company Secretaries
CS P. Eswaramoorthy

Proprietor

Coimbatore
 30th May, 2017

FCS No. : 6510

CP No. : 7069

ANNEXURE "B" TO DIRECTOR'S REPORT ANNUAL REPORT ON CORPORATE SOCIAL RESPONSIBILITY (CSR) ACTIVITIES

(as per annexure attached to the Companies (Corporate Social Responsibility Policy) Rules, 2014)

- A brief outline of the Company's CSR policy, including overview of projects or programs proposed to be undertaken and a reference to the web-link to the CSR policy and projects or programs.**

Through Pricol's long standing commitment to service to the society, we strive to attain leadership in our business through a socially and environmentally responsible way, while taking care of the interests of our stakeholders.

We work with the primary objective of contributing to the sustainable development of the society and creating a greener and cleaner environment around us. Towards achieving these objectives, Pricol has initiated "We Care", a program which executes various social and environmental development activities in and around its operational locations.

The main objective of Pricol's CSR policy is to lay down guidelines for the community centric activities taken up by Pricol for the sustainable development of the society and the environment around it. In alignment with the vision of the Company, Pricol, through its CSR initiatives, will strive to enhance value to the society and the environment through continuous initiatives. Pricol will directly or indirectly take up projects in and around its operational locations in keeping with the laid out guidelines.

Web Link to the CSR Policy:

<http://www.pricol.com/CSR-Policy.pdf>

- CSR Committee has Mrs. Vanitha Mohan, Mr. Vikram Mohan and Mr. C.R.Swaminathan as its members.**
- Average Net Profit / (Loss) of the Company for last three financial years ₹ (1.717) Million**
- Prescribed CSR Expenditure** NIL
(two per cent of the amount as in item 3 above)
- Details of CSR spent during the financial year**
 - Total amount spent for the financial year ₹ **3,758,537**
 - Amount unspent, if any ; ₹ **191,713**

ANNEXURE “B” TO DIRECTORS' REPORT (Contd.,)

c) Manner in which the amount spent during the financial year is detailed below:

in ₹

S. No.	CSR Project or Activity Identified	Sector in which the Project is covered	Projects or Programs (1) Local area or Other (2) Specify the state and district where projects or programs was undertaken	Amount Outlay (budget) project or programs wise	Amount Spent on the projects or programs (by implementing agency)	Cumulative expenditure from 1-4-2014 to 31-3-2017	Amount Spent : Direct or through implementing agency
1	Eye & Medical Camps (Government School & Public)	Health	Coimbatore, Tamilnadu	250,000	218,393	409,209	ND Foundation
2	Water Purifiers and AMC Charges	Health	Coimbatore & Tirupur, Tamilnadu	250,000	225,000	1,117,009	
3	Fire Safety and First Aid Training - To School Students	Education	Coimbatore, Tamilnadu	—	—	136,790	
4	Science & Computer Lab Facilities at Government Schools	Education	Tirupur, Tamilnadu	400,000	316,294	316,294	
5	Construction of Maternity ward at Primary Health Centre	Health and Sanitation	Tirupur, Tamilnadu	1,200,000	1,117,634	2,009,041	
6	Tree Park Construction	Environment	Coimbatore, Tamilnadu	270,000	263,466	683,316	
7	De-sitling and repair of check dam	Environment	Coimbatore, Tamilnadu	—	—	500,000	
8	Contribution to Wild Life SOS	Environment	Delhi	600,000	600,000	1,430,000	
9	Contribution to Siruthuli	Environment	Coimbatore, Tamilnadu	500,000	500,000	500,000	
10	Contribution for Corpus (Trauma Care Centre)	Health	Coimbatore, Tamilnadu	—	—	3,200,000	
11	Supply of Medical Equipments	Health					Pricol Limited
	a. To Rapid Action Force		Coimbatore, Tamilnadu	70,000	67,500	67,500	
	b. To Government Hospital		Pantnagar, Uttarakhand	210,000	210,000	210,000	
12	Supply of Safety related materials to City Police	Safety	Coimbatore, Tamilnadu	250,000	240,250	240,250	
13	Flood Relief Chennai	Health / Environment	Cuddalore, Tamilnadu	—	—	2,307,168	
			Total	4,000,000	3,758,537	13,126,577	

CSR implementing agency: ND Foundation

Note : During the year, 2016-17, the company contributed ₹ 3.500 Million to ND foundation, out of which ₹ 3.308 Million was spend by them.

6. In case the Company has failed to spend the two per cent of the average net profit of the last three financial years or any part thereof, the Company shall provide the reasons for not spending the amount in its Board report.

Not applicable

7. The CSR Committee of the Company hereby confirms that the implementation and monitoring of the CSR Policy, is in compliance with the CSR objectives and Policy of the Company.

Coimbatore
16th May, 2017

Vikram Mohan
Managing Director
(DIN : 00089968)

Vanitha Mohan
Chairman, CSR Committee
(DIN : 00002168)

ANNEXURE "C" TO DIRECTORS' REPORT

THE CONSERVATION OF ENERGY, TECHNOLOGY ABSORPTION AND FOREIGN EXCHANGE EARNINGS AND OUTGO

[Statement pursuant to Section 134(3)(m) of The Companies Act, 2013, read with Rule 8(3) of The Companies (Accounts) Rules, 2014]

A. CONSERVATION OF ENERGY :

i) the steps taken or impact on conservation of energy

The following steps were taken on the energy conservation

- Using LED lightings
- Using of 5% of the natural lights for the shop floors
- Using Variable Refrigerant Flow (VRF) Technology - Energy Efficient Air Conditioners
- Using the High Volume Low Speed (HVLS) Large Fans for the Shop floors
- Zero water loss cooling towers for the utility areas

ii) the steps taken by the company for utilising alternate sources of energy

Roof Solar system implemented as follows:

- 150 KW fixed at Plant - II - Gurugram
- 350 KW fixed at Plant - V - Pune
- 1000 KW fixed at Plant - III - Coimbatore

iii) the capital investment on energy conservation equipment's

During the year ₹ 18 Million was spent towards LED lights, VRF Technology Air Conditioners, Modular Aluminium Compressed Air Pipe Line System, HVLS Fans and Zero Water Loss Cooling towers.

B. TECHNOLOGY ABSORPTION :

I. Research and Development (R&D)

i) Specific areas of R&D

The Company has two R&D centers, which are approved by the Department of Scientific and Industrial Research (DSIR), Ministry of Science and Technology, Government of India, New Delhi. Our R&D is engaged in several areas of technology research and development as outlined below. In addition, it is also engaged in indigenization and horizontal deployment of technologies either acquired or mutually developed with associates.

There are 21 inventions filed at various jurisdictions, i.e., India and Abroad. Out of which 6 are granted and remaining are under review, the Company continues to foster innovation for growth, across all product development functions.

- Design and development of new products with emerging technologies.
- Design quality and feature enhancements in existing products through technology migration.
- Apply value engineering approach for design to cost target in product development for competitive advantage in cost and quality.
- Engineering emerging technologies in display instrumentation, sensing and integrating telematics applications in automotive requirements.
- Advanced engineering to develop technologies in electro-mechanical actuation domains, auto clutch & auto

transmission system and power train products to meet global emission norms and fuel efficiency requirements.

- Collaborate and drive technology deployment in manufacturing processes to complement innovative design solutions for market growth.
- Build and foster domain expertise in the areas of Automotive Infotainment Displays, Human Machine Interface (HMI) and sensing technologies for green transportation initiatives and body control modules towards automotive safety and comfort.

ii) Benefits derived from R&D

- Helps to meet and exceed customer targets on quality, cost and delivery of new products and its variants.
- Ensures development and delivery of new products with state of the art technologies.
- Complements new product development for market competitiveness and sustenance through value engineering methods to meet the target cost and quality requirements.
- Identify and implement emerging technologies and production processes and their horizontal deployment in applicable products.
- Develops products with validated Intellectual Property Rights (IPR) and regulations through benchmark studies, to enable risk free product implementation.

iii) In-house R&D and Future plan of action

- To cater to the present OEM BS IV and future BS VI emission norms, our Company has already initiated development of products to assist in emission reduction & fuel efficiency improvements.
- We are developing advanced telematics & analytics to enhance user experience.
- To reduce driver fatigue, especially in the tractor segment, our Company is actively working with an OEM to develop a new product.
- New generation Driver display systems using TFT displays have been developed / under development. This will help in enhancing our exports.

Expenditure on R & D 2016-17	(₹ Million)
Capital	32.294
Revenue	350.569
Total	382.863
R & D expenditure as a percentage of sales	3.15%

II. Technology Absorption, Adaptation and Innovation Imported Technology

No imported technology was acquired during the year.

C. FOREIGN EXCHANGE EARNINGS AND OUTGO

During the year, the Company's foreign exchange earnings were ₹ 812.865 Million (₹ 12.549 Million in 2015-16). The revenue expenditure in foreign currency was ₹ 2,118.513 Million (₹ 387.965 Million in 2015-16) and the capital expenditure was ₹ 168.859 Million (₹ Nil in 2015-16).

The Company will continue its efforts to enhance the export sales.

ANNEXURE "D" TO DIRECTORS' REPORT

Form No. MGT - 9
EXTRACT OF ANNUAL RETURN
as on the financial year ended 31st March, 2017

[Pursuant to section 92(3) of the Companies Act, 2013 and rule 12(1) of the Companies (Management and Administration) Rules, 2014]

I. REGISTRATION AND OTHER DETAILS :

- i) **CIN** : L34200TZ2011PLC022194
- ii) **Registration Date** : 18th May 2011
- iii) **Name of the Company** : Pricol Limited (Formerly Pricol Pune Limited)
- iv) **Category / Sub-Category of the Company** :
Company limited by shares / Indian Non – Government Company
- v) **Address of the Registered office and contact details** :
109, Race Course, Coimbatore – 641 018, India
Phone : +91 422 4336000
Fax : +91 422 4336299
E-mail : cs@pricol.co.in.
- vi) **Whether Listed Company** : Yes / No
- vii) **Name, Address and Contact details of Registrar and Transfer Agent, if any** :
Integrated Registry Management Services (P) Ltd.
Unit : Pricol Limited, 2nd Floor, "Kences Towers",
No.1, Ramakrishna Street, North Usman Road,
T. Nagar, Chennai - 600 017, India.
Phone : +91 44 28140801-03
Fax : +91 44 28142479
Email : srirams@integratedindia.in

II. PRINCIPAL BUSINESS ACTIVITIES OF THE COMPANY :

All the business activities contributing 10% or more of the total turnover of the Company

Sl. No.	Name and Description of main products / services	NIC Code of the product / service	% to total turnover of the Company
1	Oil Pumps	28132	10
2	Auto Components - Motor Vehicles	29301 & 29304	29
3	Auto Components - Motor Cycles and Three Wheelers	30913	46

III. PARTICULARS OF HOLDING, SUBSIDIARY AND ASSOCIATE COMPANIES :

Name, Address & CIN / GLN of the Company	% of shares held	Applicable Section
I Subsidiary Company		
1 PT Pricol Surya Indonesia J 1, Permata Raya Lot FF-2, KIIC Industrial Park, Karawang 41361, Indonesia. Regn. No. - C-34667HT.01.01.TH.2005	100	2 (87)
2 Pricol Asia Pte. Limited 17 Phillip Street, #05-01 Grand Building, Singapore 048695. Regn. No. - 201221194R	100	2 (87)
3 Pricol Espana Sociedad Limitada Calle Pensamirnto, 27 Escalera Izquierda, 3a Planta, Puerta 3, 28020 Madrid, Spain. CNPJ-21.671.518 0001.27	100	2 (87)
4 Pricol Do Brasil Componentes Automotivos Ltda A AG.0403, CC. 00137-82 Av,Fukuichi,381,Piraporinha, Diadema, Sao Paulo, Brazil CNPJ - 07.765.200 0001.84	100	2 (87) Subsidiary of Pricol Espana Sociedad Limitada
II Holding and Associate Company	—	—

ANNEXURE "D" TO DIRECTORS' REPORT (Contd.,)

IV. SHAREHOLDING PATTERN (Equity Share Capital Breakup as percentage of Total Equity)

i) Category - wise Share Holding

Category of share holders	No. of shares held at the beginning of the year *				No. of shares held at the end of the year **				% of change during the year
	Demat	Physical	Total	% of total shares	Demat	Physical	Total	% of total shares	
A. Promoters									
1) Indian									
a) Individual / HUF	—	—	—	—	24,734,945	—	24,734,945	26.09	NA
b) Central Government	—	—	—	—	—	—	—	—	NA
c) State Government(s)	—	—	—	—	—	—	—	—	NA
d) Bodies Corporate	—	100,000,000	100,000,000	100.00	10,587,051	—	10,587,051	11.17	NA
e) Banks / FI	—	—	—	—	—	—	—	—	NA
f) Any Other	—	—	—	—	—	—	—	—	NA
Sub-total (A) (1):-	—	100,000,000	100,000,000	100.00	35,321,996	—	35,321,996	37.26	NA
2) Foreign									
a) NRIs - Individuals	—	—	—	—	—	—	—	—	NA
b) Other-Individuals	—	—	—	—	—	—	—	—	NA
c) Bodies Corporates	—	—	—	—	—	—	—	—	NA
d) Banks / FI	—	—	—	—	—	—	—	—	NA
e) Any Other	—	—	—	—	—	—	—	—	NA
Sub-total (A) (2) :-	—	—	—	—	—	—	—	—	NA
Total shareholding of Promoter (A) = (A) (1) + (A) (2)	—	100,000,000	100,000,000	100.00	35,321,996	—	35,321,996	37.26	NA
B. Public Shareholding									
1) Institutions									
a) Mutual Funds	—	—	—	—	1,688,402	750	1,689,152	1.78	NA
b) Banks / FI	—	—	—	—	15,050	125	15,175	0.02	NA
c) Central Government	—	—	—	—	—	—	—	—	NA
d) State Government(s)	—	—	—	—	—	—	—	—	NA
e) Venture Capital Funds	—	—	—	—	—	—	—	—	NA
f) Insurance Companies	—	—	—	—	268,966	—	268,966	0.28	NA
g) FIs —	—	—	—	—	—	—	—	—	NA
h) Foreign Venture Capital Funds - Portfolio investors	—	—	—	—	1,687,778	—	1,687,778	1.78	NA
i) Others	—	—	—	—	—	—	—	—	NA
Sub-total (B) (1) :-	—	—	—	—	3,660,196	875	3,661,071	3.86	NA
2) Non-Institutions									
a) Bodies Corporate	—	—	—	—	—	—	—	—	—
i) Indian	—	—	—	—	15,141,069	15,940	15,157,009	15.99	NA
ii) Overseas	—	—	—	—	—	—	—	—	NA
b) Individuals	—	—	—	—	—	—	—	—	—
i) Individual shareholders holding nominal share capital upto ₹ 1 lakh	—	—	—	—	31,315,324	2,526,809	33,842,133	35.70	NA
ii) Individual shareholders holding nominal share capital in excess of ₹1 lakh	—	—	—	—	5,374,872	—	5,374,872	5.67	NA
c) Others (specify)	—	—	—	—	—	—	—	—	NA
i) Non Resident Indians	—	—	—	—	1,402,010	37,500	1,439,510	1.52	NA
ii) Trust	—	—	—	—	130	—	130	—	NA
Sub-total (B)(2):-	—	—	—	—	53,233,405	2,580,249	55,813,654	58.88	NA
Total Public Shareholding (B) = (B) (1) + (B) (2)	—	—	—	—	56,893,601	2,581,124	59,474,725	62.74	NA
C. Shares held by Custodian for GDRs & ADRs	—	—	—	—	—	—	—	—	—
Grand Total (A + B + C)	—	100,000,000	100,000,000	100.00	92,215,597	2,581,124	94,796,721	100.00	NA

* Equity Shares held by holding company, erstwhile Pricol Limited.

** Reflects the number of Equity Shares that have since been allotted under the Scheme of Amalgamation

ANNEXURE "D" TO DIRECTORS' REPORT (Contd.,)

ii) Shareholding of Promoters

Sl. No.	Shareholder's Name	Shareholding at the beginning of the year *			Shareholding at the end of the year **			
		No. of Shares	% of total shares of the Company	% of shares Pledged / encumbered to total shares	No. of Shares	% of total shares of the Company	% of shares Pledged / encumbered to total shares	% Change in shareholding during the year
1	Erstwhile Pricol Limited	100,000,000	100.00	—	—	—	—	NA
1	Vijay Mohan	—	—	—	9,140,278	9.64	—	NA
2	Vijay Mohan (BHUF)	—	—	—	660,900	0.70	—	NA
3	Vanitha Mohan	—	—	—	3,726,488	3.93	—	NA
4	Vikram Mohan	—	—	—	3,521,175	3.71	—	NA
5	Viren Mohan	—	—	—	6,658,409	7.02	—	NA
6	Madhura Mohan	—	—	—	181,575	0.19	—	NA
7	Manasa Mohan	—	—	—	150,000	0.16	—	NA
8	T Balaji Naidu	—	—	—	975	—	—	NA
9	Gayathri Balaji	—	—	—	159,995	0.17	—	NA
10	Vinay Balaji	—	—	—	100,000	0.11	—	NA
11	Uday Balaji	—	—	—	22,005	0.02	—	NA
12	Sumanth R	—	—	—	332,145	0.35	—	NA
13	Sumanth R (BHUF)	—	—	—	81,000	0.09	—	NA
14	Pricol Holdings Limited	—	—	—	8,556,926	9.03	—	NA
15	Bhavani Infin Services India Private Limited	—	—	—	1,498,790	1.58	—	NA
16	Sagittarius Investments Private Limited	—	—	—	340,935	0.36	—	NA
17	Shrimay Enterprises Private Limited	—	—	—	190,400	0.20	—	NA
	Total	100,000,000	100.00	—	35,321,996	37.26	—	NA

* Equity Shares held by holding company, erstwhile Pricol Limited.

** Reflects the number of Equity Shares that have since been allotted under the Scheme of Amalgamation.

ANNEXURE "D" TO DIRECTORS' REPORT (Contd.,)

iii) Change in Promoters' Shareholding

Name of the Shareholder	Shareholding at the beginning of the year *		Cumulative Shareholding during the year **	
	No. of shares	% of total shares	No. of shares	% of total shares
1 Erstwhile PRICOL LIMITED				
As on 01-04-2016	100,000,000	100	—	—
Cancelled due to scheme of Amalgamation 01-11-2016	100,000,000	100	—	—
As on 31-03-2017			—	—
Under the Scheme of Amalgamation, the promoters of listed entity (erstwhile Pricol Limited) were considered as Promoters of the company. As on 01-04-2016 the following persons who are the Promoters do not hold any shares of the company. On 07-12-2016 Equity Shares allotted based on the Shareholding in erstwhile Pricol Limited on the Record Date 06-12-2016.				
1 Vijay Mohan	—	—	9,140,278	9.64
2 Vijay Mohan (BHUF)	—	—	660,900	0.70
3 Vanitha Mohan	—	—	3,726,488	3.93
4 Vikram Mohan	—	—	3,521,175	3.71
5 Viren Mohan	—	—	6,658,409	7.02
6 Madhura Mohan	—	—	181,575	0.19
7 Manasa Mohan	—	—	150,000	0.16
8 T Balaji Naidu	—	—	975	—
9 Gayathri Balaji	—	—	159,995	0.17
10 Vinay Balaji	—	—	100,000	0.11
11 Uday Balaji	—	—	22,005	0.02
12 Sumanth R	—	—	332,145	0.35
13 Sumanth R(BHUF)	—	—	81,000	0.09
14 Pricol Holdings Limited	—	—	8,556,926	9.03
15 Bhavani Infin Services India Private Limited	—	—	1,498,790	1.58
16 Sagittarius Investments Private Limited	—	—	340,935	0.36
17 Shrimay Enterprises Private Limited	—	—	190,400	0.20

iv) Shareholding Pattern of top ten Shareholders (other than Directors, Promoters and Holders of GDRs and ADRs) :

Name of the Shareholder	Shareholding at the beginning of the year *		Cumulative Shareholding during the year **	
	No. of shares	% of total shares	No. of shares	% of total shares
As on 01-04-2016 the following persons do not hold any shares of the company.				
Under the Scheme of Amalgamation, on 07-12-2016 Equity Shares allotted based on the Shareholding in erstwhile Pricol Limited on the Record Date 06-12-2016.				
1 VRAMATH FINANCIAL SERVICES PVT LTD				
PAN : AAECV1452G				
As on 07-12-2016	4,570,126	4.82		
(Proprietary A/c)				
Trading are carried out in Trading Member A/c.				
Purchase 17-02-2017	15,357	0.02	4,585,483	4.84
Sale 24-02-2017	-15,920	-0.02	4,569,563	4.82
Sale 03-03-2017	-1,802	—	4,567,761	4.82
Purchase 17-03-2017	321	—	4,568,082	4.82
Purchase 24-03-2017	7,700	0.01	4,575,782	4.83
Sale 31-03-2017	-7,823	-0.01	4,567,959	4.82
As on 31-03-2017			4,567,959	4.82
2 PHI CAPITAL SOLUTIONS LLP				
PAN : AAMFP6305R				
As on 07-12-2016	4,499,000	4.75		
As on 31-03-2017			4,499,000	4.75
3 RAJESH MADHAVAN UNNI (HUF)				
PAN : AAPHR9418E				
As on 07-12-2016	1,947,701	2.06		
As on 31-03-2017			1,947,701	2.06
4 UTI LONG TERM ADVANTAGE FUNDS II				
PAN : AAATU1088L				
As on 07-12-2016	1,688,402	1.78		
As on 31-03-2017			1,688,402	1.78
5 AKG FINVEST LTD				
PAN : AADCA8306P				
As on 07-12-2016	681,000	0.72		
Purchase 17-02-2017	1,000	—	682,000	0.72
Purchase 17-03-2017	35,000	0.04	717,000	0.76
Purchase 31-03-2017	7,678	0.01	724,678	0.76
As on 31-03-2017			724,678	0.76
6 GOLDMAN SACHS (SINGAPORE) PTE				
PAN : AAFCG0345N				
As on 09-12-2016	613,197	0.65		
As on 31-03-2017			613,197	0.65

ANNEXURE "D" TO DIRECTORS' REPORT (Contd.,)

Name of the Shareholder	Shareholding at the beginning of the year*		Cumulative Shareholding during the year**	
	No. of shares	% of total shares	No. of shares	% of total shares
7 SEEMA GOEL PAN : AHAPG8015A				
As on 07-12-2016	290,000	0.31		
As on 31-03-2017			290,000	0.31
8 UNITED INDIA INSURANCE CO. LIMITED PAN : AAACU5552C				
As on 07-12-2016	268,966	0.28		
As on 31-03-2017			268,966	0.28
9 VALLIEMMAI SP R PAN : AAZPV9704H				
As on 07-12-2016	267,136	0.28		
17-12-2016	-8485	-0.01	258,651	0.27
23-12-2016	8485	0.01	267,136	0.28
As on 31-03-2017			267,136	0.28
10 ANIL KUMAR GOEL PAN : AAJPG2552Q				
As on 07-12-2016	238,908	0.25		
As on 31-03-2017			238,908	0.25

v) Shareholding of Directors and Key Managerial Personnel :

Name of the Shareholder	Shareholding at the beginning of the year *		Cumulative Shareholding during the year **	
	No. of shares	% of total shares	No. of shares	% of total shares
As on 01-04-2016 the following persons do not hold any shares of the company.				
Under the Scheme of Amalgamation, on 07-12-2016 Equity Shares allotted based on the Shareholding in erstwhile Pricol Limited on the Record Date 06-12-2016.				
1 Mr. Vijay Mohan - Chairman				
As on 07-12-2016	9,140,278	9.64		
As on 31-03-2017			9,140,278	9.64
2 Mr. Vijay Mohan (BHUF)				
As on 07-12-2016	660,900	0.70		
As on 31-03-2017			660,900	0.70
3 Mrs. Vanitha Mohan - Vice Chairman				
As on 07-12-2016	3,726,488	3.93		
As on 31-03-2017			3,726,488	3.93
4 Mr. Vikram Mohan - Managing Director				
As on 07-12-2016	3,521,175	3.71		
As on 31-03-2017			3,521,175	3.71
5 Mr. Suresh Jagannathan - Independent Director				
As on 07-12-2016	26,985	0.03		
As on 31-03-2017			26,985	0.03

Name of the Shareholder	Shareholding at the beginning of the year *		Cumulative Shareholding during the year **	
	No. of shares	% of total shares	No. of shares	% of total shares
6 Mr. C.R. Swaminathan - Independent Director				
As on 07-12-2016	1,995	—		
As on 31-03-2017			1,995	—
7 Mr. R. Vidhya Shankar - Independent Director				
As on 07-12-2016	—	—		
As on 31-03-2017			—	—
8 Mr. G. Soundararajan - Independent Director				
As on 07-12-2016	—	—		
As on 31-03-2017			—	—
9 Mr. K. Murali Mohan - Independent Director				
As on 07-12-2016	—	—		
As on 31-03-2017			—	—
10 Mrs. Sriya Chari - Independent Director				
As on 07-12-2016	—	—		
As on 31-03-2017			—	—
11 Mr. S. Shrinivasan - Chief Financial Officer				
As on 07-12-2016	—	—		
As on 31-03-2017			—	—
12 Mr. T. G.Thamizhanban - Company Secretary				
As on 07-12-2016	—	—		
As on 31-03-2017			—	—

* Equity Shares held by holding company, erstwhile Pricol Limited.

** Reflects the number of Equity Shares that have since been allotted under the Scheme of Amalgamation

V. INDEBTEDNESS

Indebtedness of the Company including interest outstanding / accrued but not due for payment

₹ Million

Particulars	Secured Loans excluding Deposits	Un-secured Loans	Deposits	Total
As at 01-04-2016				
i) Principal Amount	20.000	—	—	20.000
ii) Interest due but not paid	—	—	—	—
iii) Interest accrued but not due	0.199	—	—	0.199
Total (i + ii)	20.199	—	—	20.199
Change during the financial year				
i) Addition	1,466.799	1,201.099	—	2,667.898
ii) Reduction	600.291	1,000.000	—	1,600.291
Net Change (i - ii)	866.508	201.099	—	1,067.607
As at 31-03-2017				
i) Principal Amount	883.474	200.000	—	1,083.474
ii) Interest due but not paid	—	—	—	—
iii) Interest accrued but not due	3.233	1.099	—	4.332
Total (i + ii)	886.707	201.099	—	1,087.806

ANNEXURE "D" TO DIRECTORS' REPORT (Contd.,)

VI. REMUNERATION OF DIRECTORS AND KEY MANAGERIAL PERSONNEL

A. Remuneration to Managing Director, Whole-time Directors and / or Manager :

₹ Million

Particulars of Remuneration	Name of MD / WTD / Manager		Total Amount
	Mr. Vikram Mohan (Managing Director)	Mrs. Vanitha Mohan (Vice Chairman)	
1. Gross salary			
a) Salary as per provisions contained u/s 17(1) of the Income Tax Act, 1961	11.520	4.608	16.128
b) Value of perquisites u/s 17(2) Income Tax Act, 1961	4.580	1.772	6.352
c) Profits in lieu of salary u/s 17(3) Income Tax Act, 1961	—	—	—
2. Stock Option	—	—	—
3. Sweat Equity	—	—	—
4. Commission			
- as % of profit	13.448	10.086	23.534
- others	—	—	—
5. Others (Contribution to PF, Gratuity and Superannuation Fund)	0.964	0.446	1.410
Total(A)	30.512	16.912	47.424
Ceiling as per the Act	33.619	33.619	67.238
1. In case of adequate profit	(5% of the Net Profit)	(5% of the Net Profit)	(10% of the Net Profit)
2. In case of no profit or inadequate profit	₹ 13 Million	₹ 13 Million	₹ 26 Million
	plus contribution to PF, Superannuation, Gratuity, Encashment of leave to the extent permitted under the Act		

B. Remuneration to other directors :

₹ Million

Particulars of Remuneration	Mr.C.R.Swami nathan	Mr.K.Murali Mohan	Mr. Suresh Jagannathan	Mr. R. Vidhya Shankar	Mr.G.Soundara rajan	Mrs.Sriya Chari	Mr.Vijay Mohan	Mr. S. A. Gopala Krishnan	Mr.N.Subramanian	Total Amount
1. Independent Directors										
Fee for attending board / committee meetings	0.240	0.220	0.065	0.225	0.065	0.045	—	0.020	0.020	0.900
Commission	0.570	0.530	0.160	0.540	0.160	0.110	—	—	—	2.070
Others	—	—	—	—	—	—	—	—	—	—
Total (1)	0.810	0.750	0.225	0.765	0.225	0.155	—	0.020	0.020	2.970
2. Other Non-Executive Directors										
Fee for attending board / committee meetings	—	—	—	—	—	—	0.150	—	—	0.150
Commission	—	—	—	—	—	—	0.350	—	—	0.350
Others	—	—	—	—	—	—	—	—	—	—
Total (2)	—	—	—	—	—	—	0.500	—	—	0.500
Total (B) = (1+2)	0.810	0.750	0.225	0.765	0.225	0.155	0.500	0.020	0.020	3.470

C. Total Managerial Remuneration (A+B) : ₹ 50.894 Million

Overall Ceiling as per the Act : 11% of the Net Profits of the Company as calculated under section 198. The said percentage shall be exclusive of any fees payable to directors under Section 197(5).

ANNEXURE "D" TO DIRECTORS' REPORT (Contd.,)

D. Remuneration to Key Managerial Personnel other than MD / MANAGER / WTD

Particulars of Remuneration	Key Managerial Personnel		Total
	Mr. S. Shrinivasan (CFO)	Mr. T. G. Thamizhanban (CS)	
1. Gross salary	₹ Million		
a) Salary as per provisions contained u/s 17(1) of the Income Tax Act, 1961	3.743	2.091	5.834
b) Value of perquisites u/s 17(2) Income Tax Act, 1961	—	—	—
c) Profits in lieu of salary u/s 17(3) Income Tax Act, 1961	—	—	—
2. Stock Option	—	—	—
3. Sweat Equity	—	—	—
4. Commission	—	—	—
- as % of profit	—	—	—
- others	—	—	—
5. Others (Contribution to PF, Gratuity, Superannuation and Service Weightage)	0.991	0.344	1.335
Total	4.734	2.435	7.169

VII. PENALTIES / PUNISHMENT / COMPOUNDING OF OFFENCES:

Type	Section of the Companies Act	Brief Description	Details of Penalty / Punishment / Compounding fees imposed	Authority (RD / NCLT / COURT)	Appeal made
A. COMPANY					
Penalty	—	—	—	—	—
Punishment	—	—	—	—	—
Compounding	—	—	—	—	—
B. DIRECTORS					
Penalty	—	—	—	—	—
Punishment	—	—	—	—	—
Compounding	—	—	—	—	—
C. OTHER OFFICERS IN DEFAULT					
Penalty	—	—	—	—	—
Punishment	—	—	—	—	—
Compounding	—	—	—	—	—

ANNEXURE "E" TO DIRECTORS' REPORT

Particulars of Remuneration of Directors and Employees pursuant to Section 197(12) of the Companies Act, 2013 read with the Companies (Appointment and Remuneration) Rules, 2014.

i) The ratio of the remuneration of each director to the median remuneration of the employees of the Company for the financial year.

S.No.	Name of the Director	No. of Meetings attended	Ratio
1	Mr. Suresh Jagannathan	4	0.43
2	Mr. C. R. Swaminathan	21	1.55
3	Mr. R. Vidhya Shankar	18	1.46
4	Mr. G. Soundararajan	4	0.43
5	Mr. K. Murali Mohan	17	1.44
6	Mrs. Sriya Chari	3	0.30
7	Mr. D. Sarath Chandran (retired w.e.f.27th May, 2016)	—	—
8	Mr. Vijay Mohan	15	0.96
9	Mr. S. A. Gopala Krishnan	8	0.04
10	Mr. N. Subramanian	8	0.04

S.No.	Name of Whole Time Director	Ratio
1	Mrs. Vanitha Mohan, Vice Chairman	32.37
2	Mr. Vikram Mohan, Managing Director	58.41

ii) The percentage increase in remuneration of each Director, Chief Financial Officer (CFO), Chief Executive Officer (CEO), Company Secretary (CS) or Manager, if any, in the financial year

S. No.	Name of Non Whole Time Director	No. of meeting attended		% Increase / (Decrease) in remuneration
		2016-17	2015-16	
1	Mr. Suresh Jagannathan	4	3	45.16
2	Mr. C.R.Swaminathan	21	19	11.72
3	Mr. R.Vidhya Shankar	18	20	(10.00)
4	Mr. G.Soundararajan	4	4	—
5	Mr. K.Murali Mohan	17	11	23.97
6	Mrs. Sriya Chari	3	—	NA
7	Mr. D.Sarath Chandran (retired w.e.f.27th May, 2016)	—	6	NA
8	Mr. Vijay Mohan	15	15	—
9	Mr. S.A.Gopala Krishnan	8	12	66.67
10	Mr. N.Subramanian	8	12	66.67

S. No.	Name of Whole Time director / CFO / CEO / CS	% Increase / (Decrease) in remuneration
1	Mrs. Vanitha Mohan, Vice Chairman	3.56
2	Mr. Vikram Mohan, Managing Director	6.69
3	Mr. Shrinivasan S (CFO) from 1st Sep 2015	NA*
4	Mr. T. G.Thamizhanban (CS)	7.65

* Not applicable since he worked part of the year during 2015-16

ANNEXURE “E” TO DIRECTORS' REPORT (Contd.,)

Whole Time Directors receive remuneration by way of Salary, Allowances, Perquisites and Benefits (fixed component) and commission on net profit (variable component), as approved by shareholders.

Non-Whole Time Directors receive remuneration by way of sitting fees and commission on net profit, which will be paid broadly on the basis of Board Meetings and Committee Meetings attended by them.

iii) **The percentage increase in the median remuneration of employees (Staff) in the financial year** 7.89%

iv) **The number of permanent employees (Staff) on the rolls of Company** 634

vi) **The key parameters for any variable component of remuneration availed by the directors** The Directors are not eligible for any variable compensation other than Commission as per the provisions of the Act.

vii) **We affirm that the remuneration paid to Directors, Key Managerial Personnel and employees is as per the remuneration policy approved by the Board of Directors of the Company.**

xiii) **Statement of top Ten employees in terms of remuneration drawn and the name of every employee receiving remuneration not less than Eight lakh and Fifty thousand rupees per month :**

Name & (Age)	Designation (Nature of Duties)	Remuneration (₹ Million)		Qualification & Experience (Years)	Date of Commencement of Employment	Last Employment
		Gross	Net			
Mrs. Vanitha Mohan (64)	Vice Chairman (Internal Audit and Corporate Social Responsibilities)	16.912	9.837	Commerce Graduate with PG Diploma in Business Management (31)	1st June, 1999	---
Mr. Vikram Mohan (42)	Managing Director (Strategy, Finance, Customer Relationship Management and HR)	30.512	16.963	Bachelor of Engineering (Production Engineering) (21)	7th November, 2011	Pricol Corporate Services Limited
Mr. G.Sundararaman (50)	President (Responsible for Engineering and Manufacturing activities)	10.760	6.100	B.E., (Mechanical) & PG Diploma in Business Administration (28)	27th July, 2015	Royal Enfield (Unit Eicher Motors Ltd.)
Mr. Amit Bhushan Dakshini (46)	Chief Strategy Officer (Responsible for Strategy)	5.596	4.240	B.Sc., M.B.A (21)	20th April, 2016	Varroc Engg. (P) Limited
Mr. PM Ganesh (48)	Chief Marketing Officer (Responsible for Business Development)	5.367	3.404	B.E., MBA (29)	17th January, 2013	Lucas TVS Limited
Mr. V.Balaji Chinnappan (52)	Vice President (Responsible for Operations of all Plants)	4.742	3.335	B.E., MBA (30)	9th April, 2007	Roots Industries Limited
Mr. Tarun Tandon (44)	Senior General Manager (Responsible for Operations - Plant II)	4.742	3.230	B.E., SMP, DMM (23)	16th October, 2009	Mahle Filter Systems India Limited
Mr. Shrinivasan.S (44)	Chief Finance Officer (Responsible for Finance)	4.734	3.266	B.Com., CMA (USA) ACMA (24)	27th July, 2015	Archean Chemicals Industries (P) Limited
Mr. Malar Vannan. R (46)	Chief People Officer (Responsible for Human Resources)	4.713	3.097	PGDPM & MHRM, PGDBM (21)	15th July, 2015	Young Brand Apparel (P) Limited
Mr. Ramathilak. V (43)	Vice President (Responsible for Continuous Improvement)	4.286	3.003	B.Tech (23)	1st June, 2012	Tenneco Automotive (P) Limited
Mr. Udaya Bhanu. S (51)*	Vice President (Responsible for Operations - Plant III)	4.275	3.345	B.E., MS., (33)	20th June, 2016	Advik Hi Tech (P) Limited
Mr. Radhakrishnan. H (54)*	Vice President (Responsible for Operations - Plant I)	2.200	1.519	B.E., MS., (36)	3rd October, 2016	Rane NSK Steering Systems Limited

* Working for part of the year.

- NOTE:**
- Mr.Vijay Mohan, Mrs.Vanitha Mohan and Mr.Vikram Mohan are related to each other. Mrs.Vanitha Mohan is Mr.Vijay Mohan's wife and Mr.Vikram Mohan is the elder son of Mr.Vijay Mohan.
 - Mrs.Vanitha Mohan and Mr.Vikram Mohan owns more than 2% of the equity shares of the Company as on 31st March 2017.
 - Gross remuneration comprises salary, commission, allowances, monetary value of perquisites and the Company's contribution to provident fund, gratuity fund and superannuation fund.
 - Net remuneration is exclusive of contributions to provident fund, gratuity fund, superannuation fund and tax deducted.

v) **Comparison of the each remuneration of the Key Managerial Personnel (KMP) against the performance of the Company :**

KMP's Name & Designation	CTC for 2016-17 ₹ Mn	% Increase / (Decrease) in CTC (2016-17 against 2015-16)	Revenue for 2016-17 ₹ Mn	% Increase in sales (2016-17 against 2015-16)
Mr. Vikram Mohan, Managing Director	30.512	6.69		
Mr. S. Shrinivasan, Chief Financial Officer from 1st Sep 2015	4.734	*	12,684	#
Mr. T. G.Thamizhanban, Company Secretary	2.435	7.65		
Total	37.681	*		

* Not comparable since CFO had worked part of the year during 2015-16.

Not comparable due to amalgamation during 2016-17.

ANNEXURE “F” TO DIRECTORS' REPORT

REPORT ON CORPORATE GOVERNANCE

1. COMPANY'S PHILOSOPHY ON CODE OF GOVERNANCE:

Company's Philosophy on Corporate Governance envisages striving for excellence in all facets of its operations through socially and environmentally acceptable means. The Company wants to be a responsible corporate citizen and share the benefits with society and also will make its customers, employees, suppliers and shareholders feel proud of their association with the Company through highest level of fairness and transparency in its dealings.

2. BOARD OF DIRECTORS:

a. Composition of the Board:

As on 31st March 2017, the Company's Board comprised of 9 Directors. The Board consists of 2 (22%) Executive Directors of whom one is a Woman Director and 7 (78%) Non-Executive Directors, of whom 6 (67%) are Independent Directors of whom one is women director. Details are given in the table below;

The members of the Board are well-experienced professionals and industrialists. The day-to-day management and affairs are handled by Mr. Vikram Mohan, Managing Director, subject to the supervision, control and direction of the Board of Directors and is assisted by Mrs. Vanitha Mohan, Vice Chairman. The composition of the Company's Board is in conformity with the SEBI (Listing Obligations and Disclosure Requirements) Regulation, 2015.

b. Category of Directors, Attendance, other directorships and committee membership:

Name of the Director	DIN	Category	Attendance Particulars		*No. of Directorships in other Companies			No. of Committee positions held in other Companies #	
			Board Meeting	Last AGM	Public Company	Private Company	Foreign Company	Member	Chairman
Mr. Suresh Jagannathan	00011326	Non-Executive -Independent	3	—	3	4	—	2	—
Mr. C.R.Swaminathan	00002169	Non-Executive - Independent	5	—	2	1	—	2	2
Mr. R.Vidhya Shankar	00002498	Non-Executive - Independent	5	✓	1	—	—	1	—
Mr. G.Soundararajan	00037995	Non-Executive - Independent	3	—	—	6	4	—	—
Mr. K.Murali Mohan	00626361	Non-Executive - Independent	5	—	3	—	—	—	—
Mrs. Sriya Chari	07383240	Non-Executive - Independent	2	—	—	2	—	—	—
Mr. Vijay Mohan Chairman	00001843	Non-Executive - Promoter	5	✓	4	—	1	—	—
Mrs. Vanitha Mohan Vice Chairman	00002168	Executive - Promoter	4	✓	3	3	—	—	—
Mr. Vikram Mohan Managing Director	00089968	Executive - Promoter	5	✓	5	1	3	—	—

* Attendance particulars of listed entity only considered. Meetings upto 31st October 2016 – erstwhile Pricol Limited (Transferor Entity) and from 1st November 2016 to 31st March 2017 (Transferee Entity)

Chairmanship / Membership of Board Committees shall only include Audit Committee and Stakeholders Relationship Committee. As detailed in the table above, none of the directors is a member of more than Ten Board level Committees of public companies in which they are Directors nor a Chairman of more than five such Committees.

Mr. Vijay Mohan, Mrs. Vanitha Mohan and Mr. Vikram Mohan are related to each other. Mrs. Vanitha Mohan is Mr. Vijay Mohan's wife and Mr. Vikram Mohan is the elder son of Mr. Vijay Mohan. No other directors are related to each other.

The Company conducts familiarization programmes for the Independent Directors and the details of such programmes have been disclosed on the website of the Company and the web link thereto is <http://www.pricol.com/Familiarisation-programme-for-independent-directors-march-2017.pdf>. An exclusive meeting of the Independent Directors of the Company was held on 14th February, 2017 without the attendance of the Non-Independent Directors and members of the management to discuss inter alia the matters specified under Schedule IV of the Companies Act, 2013.

ANNEXURE “F” TO DIRECTORS' REPORT (Contd.,)

c. Board Meetings:

The Company, in consultation with the Directors, prepares and circulates a tentative annual calendar for the meetings of the Board and Audit Committee in order to assist the Directors in planning their schedules to participate in the meetings.

During the year 2016-17, the Board met 5 times* on 27th May 2016, 3rd August 2016, 27th October 2016, 28th November 2016 and 14th February 2017 and the gap between two meetings did not exceed 120 days.

d. Brief note on Directors seeking appointment / re-appointment at the ensuing AGM:

Mr. Vikram Mohan, 42 years of age, the Managing Director of the Company, holds a Bachelors Degree in Production Engineering with Honours from PSG College of Technology, Coimbatore. Mr. Vikram Mohan is having 21 years of experience and shall be responsible for Strategy, Finance, Customer Relationship Management and Human Resources of the Company. He was appointed on the Board of Directors of the Company on 1st June 2013. During the year 2016 - 17, he attended all the 5 Board Meetings of the Company. The remuneration in the form of salary, perquisites and commission for the year 2016 - 17 is ₹ 30.512 Million. His appointment is liable to retire by rotation. Salary, perquisites and commission will be paid in accordance with the Shareholders approval.

He is also a Director in Pricol Properties Limited, Pricol Travel Limited, Pricol Holdings Limited, PPL Enterprises Limited, M and M Enterprises (India) Limited, Pricol Espana Sociedad Limitada, Spain, Pricol Asia Pte. Limited, Singapore, PT Pricol Surya Indonesia and Infusion Hospitality Private Limited. He is a member of the CSR Committee and Investment and Borrowing Committee of the Company. He holds 3,521,175 shares in the Company.

Mr. Vijay Mohan, Mrs. Vanitha Mohan and Mr. Vikram Mohan are related to each other. Mrs. Vanitha Mohan is Mr. Vijay Mohan's wife and Mr. Vikram Mohan is the elder son of Mr. Vijay Mohan. None of the Directors or Key Managerial Personnel of the Company or their relatives except Mr. Vijay Mohan, Mrs. Vanitha Mohan, Mr. Vikram Mohan and their relatives in any way concerned or interested, financially or otherwise, in the re-appointment of Mr. Vikram Mohan.

3. AUDIT COMMITTEE:

a. The Committee is mandated with the same terms of reference as specified in Regulation 18 of the SEBI (Listing Obligations and Disclosure Requirements) Regulations, 2015 and also conforms to the provisions of Section 177 of the Companies Act, 2013.

b. **Composition, Name of Members / Chairman, Meetings held and Members present during the year 2016-2017 ***

Name of the Member	Category	* Date of Meeting / Members present			
		27th May 2016	3rd August 2016	27th October 2016	14th February 2017
Mr.R.Vidhya Shankar (Chairman)	Non-Executive- Independent	✓	✓	✓	✓
Mr.C.R.Swaminathan	Non-Executive- Independent	✓	✓	✓	✓
Mr.K.Murali Mohan	Non-Executive- Independent	✓	✓	✓	✓
Mrs.Vanitha Mohan	Executive - Promoter	✓	✓	✓	✓

c. The Company Secretary acts as the Secretary to the Committee. The President, Chief Marketing Officer, Chief Financial Officer, Internal Audit team and the Statutory Auditors of the Company are permanent invitees to the meetings of the Audit Committee. The heads of various monitoring / operating departments are invited to the meetings, as and when required to explain details about the operations.

* Particulars of listed entity only considered. Meetings upto 31st October 2016 – erstwhile Pricol Limited (Transferor Entity) and from 1st November 2016 to 31st March 2017 (Transferee Entity)

ANNEXURE “F” TO DIRECTORS' REPORT (Contd.,)

4. NOMINATION AND REMUNERATION COMMITTEE :

- a. The Committee shall formulate the criteria for determining qualifications, positive attributes and independence of a Director and recommend to the Board a policy, relating to remuneration for the Directors, Key Managerial Personnel and other employees.
- b. The Committee shall identify the persons who are qualified to become Directors / Senior Management Personnel of the Company in accordance with the criteria laid down, recommend to the Board their appointment, the remuneration including commission, perquisites and benefits payable to the Directors and their removal. It shall also carry out the evaluation of every Director's performance.
- c. **Composition, Name of Members / Chairman, Meetings held and Members present during the year 2016-2017 ***

Name of the Member	Category	* Date of Meeting / Members present			
		6th April 2016	20th May 2016	28th May 2016	14th February 2017
Mr. C.R.Swaminathan (Chairman)	Non-Executive- Independent	✓	✓	✓	✓
Mr. K.Murali Mohan	Non-Executive- Independent	✓	✓	✓	✓
Mr. R.Vidhya Shankar	Non-Executive- Independent	✓	✓	✓	✓

* Particulars of listed entity only considered. Meetings upto 31st October 2016 – erstwhile Pricol Limited (Transferor Entity) and from 1st November 2016 to 31st March 2017 (Transferee Entity)

d. Nomination and Remuneration Policy

In pursuance of the Company's policy to consider human resources as its invaluable assets, to pay equitable remuneration to all Directors, Key Managerial Personnel (KMP) and employees of the Company, to harmonize the aspirations of human resources consistent with the goals of the Company and in terms of the provisions of the Companies Act, 2013 and SEBI (Listing Obligations and Disclosure Requirements) Regulations, 2015 as amended from time to time, the policy on the nomination and remuneration of Directors, Key Managerial Personnel and Senior Management has been formulated by the Nomination and Remuneration Committee and approved by the Board of Directors.

The Objectives of the Policy are:

- I. To guide the Board in relation to the appointment and removal of Directors, Key Managerial Personnel and Senior Management.
- II. To evaluate the performance of the Directors, Key Managerial Personnel and Senior Management and provide necessary reports to the Board for their further evaluation.
- III. To recommend the Remuneration payable to the Directors, Key Managerial Personnel and Senior Management.
- IV. To provide to the Key Managerial Personnel and Senior Management, rewards linked directly to their effort, performance, dedication and achievement in relation to the Company's operations.
- V. To attract, retain, motivate and promote talent and to ensure the long term sustainability of talented managerial persons and create a competitive advantage.
- VI. To devise a policy on Board diversity.
- VII. To develop a succession plan for the Board and to regularly review the plan.

The Nomination and Remuneration policy of the Company has been disclosed on the website of the Company and the web link thereto is <http://www.pricol.com/Nomination-and-Remuneration-Policy.pdf>.

ANNEXURE “F” TO DIRECTORS' REPORT (Contd.,)

e. Performance evaluation criteria for independent directors :

Performance of independent directors has to be evaluated by the Board of Directors, based on the following criteria:

- I. Evaluation Criteria laid down under Nomination and remuneration Policy.
- II. Code of Conduct as laid down by the Board and
- III. Code of Independent Directors prescribed in Schedule IV read with Section 149 (8)

5. REMUNERATION TO DIRECTORS :

The remuneration payable to the Executive Directors is determined by the Board on the recommendation of the Nomination and Remuneration Committee with the approval of the shareholders at the Annual General Meeting. The Company pays remuneration by way of Salary, Allowances, Perquisites and Benefits (fixed component) and commission (variable component) to its Executive Directors.

The Shareholders have approved remuneration to Non-Executive directors by way of Commission not exceeding one percent of the Net profits of the Company per annum. The sitting fees and commission will be distributed broadly on the basis of Board Meetings and Committee Meetings attended by the Non-Executive Directors.

The remuneration paid / payable to the Executive Directors for the year 2016-2017 :

₹ Million

Name of the Director	Designation	Service Contract	Salary, perquisites & benefits (Gross)	Commission	Total
Mrs. Vanitha Mohan	Vice Chairman	1st April 2016 to 31st March 2018	6.826	10.086	16.912
Mr. Vikram Mohan	Managing Director	1st April 2016 to 31st March 2019	17.064	13.448	30.512

The remuneration paid / payable to the Non-Executive Directors for the year 2016-2017 and the shares held by them are given below:

₹ Million

Name of the Non-Executive Director	Commission	Sitting fee	No. of Shares held on 31st March, 2017
Mr. Vijay Mohan	0.350	0.150	9,801,178
Mr. Suresh Jagannathan	0.160	0.065	26,985
Mr. C.R. Swaminathan	0.570	0.240	1,995
Mr. R. Vidhya Shankar	0.540	0.225	—
Mr. G. Soundararajan	0.160	0.065	—
Mr. K. Murali Mohan	0.530	0.220	—
Mrs. Sriya Chari	0.110	0.045	—
Mr. S.A. Gopalakrishnan	—	0.020	—
Mr. N. Subramaniam	—	0.020	—

The Company had availed the services of Mr. R. Vidhya Shankar, Advocate who is a Non-Executive-Independent Director, in his professional capacity and paid ₹ 0.792 Million. The said transaction value does not exceed ten per cent of the gross turnover of his legal firm.

ANNEXURE “F” TO DIRECTORS' REPORT(Contd.,)

6. STAKEHOLDERS RELATIONSHIP COMMITTEE :

The Committee comprises of Mr.Vijay Mohan, Mrs.Vanitha Mohan, Mr.C.R.Swaminathan and Mr. R.Vidhya Shankar.

The Committee approves the issue of new / duplicate share certificates. The Committee oversees and reviews all matters connected with share transfers / transmission / demat / remat and other issues pertaining to shares. The Committee also looks into the investor relations / grievances and redressal of the same, on a periodical basis.

The Committee met 4 times during the year on 23rd May 2016, 27th July 2016, 19th October 2016 and 2nd February 2017. Mr.Vijay Mohan chaired the meetings. Mr. T.G.Thamizhanban, Company Secretary is the Compliance Officer.

During the year, 7 letters were received from the investors regarding non-receipt of dividend warrants / annual reports / share certificates etc., and all of them were replied / resolved to their satisfaction. No transfer / dematerialisation / investor complaints are kept pending.

7. GENERAL BODY MEETINGS :

Year	Date & Time	Special Resolution	Location
2014 - 3rd AGM	30th December, 2014 5.00 p.m.	a. Fixing Borrowing powers of the Board of Directors	Registered Office Survey No. 1065 & 1066, Pirangut (Village), Mulshi (Taluka), Pune - 412 108
2015 - 1/2015 EGM	6th May, 2015 10.00 a.m	a. Name change of Company from "Johnson Controls Pricol Private Limited" to "Pricol Pune Private Limited"	
2015 - 4th AGM	7th August, 2015 12.00 p.m.	NIL	
2015 - 2/2015 EGM	12th October, 2015 11.00 a.m.	a. Change of Registered Office of the Company	Registered Office 109 , Race Course, Coimbatore - 641 018
2016 - 1/2016 EGM	11th January, 2016 03.00 p.m.	a. Sub-division of Equity Shares b. Conversion of Private into Public Company	
2016 - 2/2016 EGM	22nd July, 2016 03.00 p.m.	a. Change in Object Clause b. Change in Articles	
2016 - 5th AGM	17th August, 2016 12.00 p.m.	NIL	
2016 - 3/2016 EGM	25th October, 2016 11.00 a.m.	a. Creation of Charge b. Fixing Borrowing powers of the Board of Directors	

- Special resolution passed during the year 2016-17, through postal ballot :**

Court convened meeting of members held during the year 2016-17: 22nd June 2016

As per the direction of the High Court of Judicature at Madras, the Company sought the approval of the Equity Shareholders by way of Special resolution under section 391(2) of the Companies Act 1956 and SEBI circulars, for the Scheme of Amalgamation of erstwhile Pricol Limited with Pricol Limited (Formerly Pricol Pune Limited).

ANNEXURE “F” TO DIRECTORS' REPORT(Contd.,)

Details of voting pattern	Number of persons / ballots	Number of shares / votes	% on votes exercised
Total votes of eligible members	30,321	94,796,721	NotApplicable
Total valid votes exercised	764	56,268,764	100.00
Votes cast for the resolution In Nos.	733	56,245,057	99.96
Votes cast against the resolution In Nos.	31	23,707	0.04

- Person who conducted the postal ballot exercise : – Mr.K.Sriram, Partner, M/s. S.Krishnamurthy & Co., Company Secretaries.

8. MEANS OF COMMUNICATION:

The quarterly / annual financial results of the Company are published in The New Indian Express (English), Business Line (English) and The Hindu (Tamil). The financial results and the annual reports of the Company are uploaded on the Company's website: www.pricol.com and on the websites, www.bseindia.com and www.nseindia.com. Periodically the Company is making presentations to institutional investors and to analysts.

Management discussion & Analysis forms part of the Annual Report.

9. GENERAL SHAREHOLDER INFORMATION:

a. Annual General Meeting

Date & Time : 23rd August, 2017, 4.30 p.m.
Venue : Chamber Hall, Chamber Towers,
8/732, Avinashi Road, Coimbatore – 641 018

b. Financial Year : 1st April, 2016 to 31st March, 2017

c. Date of Book closure : 17th August, 2017 to 23rd August, 2017

d. Financial Calendar

Financial reporting for the quarter ending	Financial Calendar
30th June, 2017	Between 15th July and 14th September 2017
30th September, 2017	Between 15th October and 14th December 2017
31st December, 2017	Between 15th January and 14th February 2018
31st March, 2018	Between 15th April and 30th May 2018

e. Particulars of Dividend payments : Dividend of ₹ 1/- per share has been recommended by the Board of Directors and subject to the approval of the shareholders at the ensuing Annual General Meeting is proposed to be paid from 24th August, 2017.

f. Listing on Stock Exchanges : **National Stock Exchange of India Limited** Exchange Plaza, C-1, Block G, Bandra Kurla Complex, Bandra (E), Mumbai - 400 051
BSE Limited Phiroze Jeejeebhoy Towers, Dalal Street, Mumbai- 400 001

g. Stock Code : National Stock Exchange : PRICOLLTD
BSE Limited : 540293

h. International Security Identification Number (ISIN) : INE726V01018

i. Listing and Custodial Fee : Annual Listing Fees for the year 2017-18 were paid to National Stock Exchange of India Limited and BSE Limited. Custodial Fees for the year 2017-18 to Central Depository Services (India) Limited and National Securities Depository Limited, were paid.

ANNEXURE “F” TO DIRECTORS' REPORT(Contd.,)

j. Stock Market Data:

Month	National Stock Exchange				BSE Limited			
	Price (₹)		CNX- 500 (Points)		Price (₹)		BSE- Small Cap (Points)	
	High	Low	High	Low	High	Low	High	Low
April-16	57.90	42.60	6695.25	6316.15	57.40	43.00	11212.69	10534.27
May-16	56.50	49.35	6842.65	6463.70	57.00	49.30	11230.86	10825.84
June-16	86.40	54.50	6990.50	6630.55	86.25	54.60	11192.31	10969.61
July-16	122.70	80.00	7357.45	7003.90	122.65	80.05	12370.86	11821.31
August-16	124.15	105.05	7520.45	7215.40	124.25	115.55	12698.47	12061.03
September-16	124.40	101.00	7647.50	7303.95	124.40	100.00	13154.81	12423.13
October-16	131.95	111.00	7605.65	7371.35	132.15	111.75	13594.67	12826.64
November-16	124.30	77.85	7539.10	6751.15	124.30	78.00	13619.30	11462.87
December-16	92.40	88.50	7112.25	6711.65	92.35	88.50	12406.31	11516.23
January-17	No Trading		7483.90	7432.10	No Trading		13170.17	12078.39
February-17	113.80	87.00	7762.60	7366.90	115.35	87.00	13703.94	12933.37
March-17	91.50	77.00	8005.75	7659.25	91.70	77.00	14447.47	13546.02

Note : Above share price indicates the price of erstwhile Pricol Limited (Transferor) upto 2nd December, 2016. Due to Amalgamation, trading was suspended from 3rd December, 2016 and started from 10th February, 2017, as amalgamated entity.

k. Registrar and Transfer Agents:

For Physical transfer and Dematerialisation of shares:

The Company has appointed M/s. Integrated Registry Management Services (P) Limited, 2nd Floor, "Kences Towers", No.1, Ramakrishna Street, North Usman Road, T. Nagar, Chennai - 600 017 as Common Transfer Agent for all aspects of investor servicing relating to shares in both physical and demat form.

l. Share Transfer System:

The Company's shares are required to be compulsorily traded in the Stock Exchanges in dematerialised form. Shares in physical mode which are lodged for transfer are processed and returned within the stipulated time, if the documents are complete in all respects. Physical shares received for dematerialisation are processed and completed within the stipulated time if the documents are complete in all respects. Bad deliveries are promptly returned to Depository Participants (DP's) under advice to shareholders. The Company obtains the following certificates from M/s. S.Krishnamurthy & Co., Company Secretaries, Chennai :

- Pursuant to Regulation 40(9) of the SEBI (Listing Obligations and Disclosure Requirements) Regulations, 2015, on half-yearly basis, for due compliance of share transfer formalities by the Share Transfer Agent of the Company.
- Pursuant to SEBI (Depositories and Participants) Regulations, 1996, on quarterly basis, to reconcile the total admitted capital with National Securities Depository Limited (NSDL) and Central Depository Services India Limited (CDSL) with the total issued / paid-up capital of the Company.

ANNEXURE “F” TO DIRECTORS' REPORT(Contd.,)

m. Shareholding pattern as on 31st March 2017 :

Shares held by	No. of holders	No. of Shares	% of Total Paid - up Capital
Promoters & Associates	17	35,321,996	37.26
Non-Resident Indians	679	1,439,510	1.52
Foreign Portfolio Investors	12	1,687,778	1.78
Banks / Indian Financial Institutions	3	15,175	0.02
Insurance Companies	1	268,966	0.28
Trust	1	130	—
Bodies Corporate	787	15,157,009	15.99
Mutual Funds	3	1,689,152	1.78
Public	43,201	39,217,005	41.37
Total	44,704	94,796,721	100.00

n. Distribution of Shareholding as on 31st March 2017:

Shareholding (Range)	No. of holders	No. of Shares	% of Total Paid - up Capital
Upto 500	34,487	5,628,434	5.94
501 to 1000	4,470	3,719,436	3.92
1001 to 2000	2,478	3,860,814	4.07
2001 to 3000	995	2,556,110	2.70
3001 to 4000	497	1,777,397	1.87
4001 to 5000	453	2,121,560	2.24
5001 to 10000	703	5,105,761	5.39
10001 and above	621	70,027,209	73.87
Total	44,704	94,796,721	100.00

o. Dematerialisation of shares and liquidity as on 31st March 2017:

Shares of the Company can be held and traded in Electronic form. As stipulated by SEBI, the shares of the Company are accepted in the Stock Exchanges for delivery only in dematerialised form.

Particulars	No. of holders	% of No. of holders	No. of Shares	% of Total Paid - up Capital
i) National Securities Depository Limited (NSDL)	28,069	62.79	71,532,984	75.46
ii) Central Depository Services (India) Limited (CDSL)	15,550	34.78	20,682,613	21.82
Demat Form (i + ii)	43,619	97.57	92,215,597	97.28
iii) Physical Form	1,085	2.43	2,581,124	2.72
Total	44,704	100.00	94,796,721	100.00

The Company's shares are regularly traded on BSE Limited and National Stock Exchange of India Limited.

p. Transfer of Unclaimed Shares to Demat Account:

In terms of the Listing Agreement entered with the Stock Exchanges, intimations have been sent to the shareholders to claim the unclaimed shares. Even after the reminders some of the shares have not been claimed by the Shareholders and as per Regulation 39 of SEBI LODR, these shares have been kept in a separate Demat Account opened for this purpose. The voting rights on these shares shall remain frozen till the rightful owner of such shares claims the shares.

ANNEXURE “F” TO DIRECTORS' REPORT(Contd.,)

Particulars		No. of shareholders	No. of shares
Opening	a	764	1,077,370
Transferred from Unclaimed Shares Suspense account upto 31st March 2016	b	60	111,050
Closing Balance as on 31st March 2016	c = a - b	704	966,320
Claimed during the year 2016-17		11	14,570
Transferred from Unclaimed Shares Suspense account during the year 2016-17	d	11	14,570
Closing Balance as on 31st March 2017	e = c - d	693	951,750

The shareholders are requested to contact the Registrar and Share Transfer Agent for claiming the shares.

q. **As on 31st March 2017, there are no Outstanding GDRs / ADRs / Warrants or any Convertible Instruments.**

r. **Commodity price risk or foreign exchange risk and hedging activities :**

Refer to Note No. 2.44 to Notes to Financial Statements.

s. **Plant locations :**

Plant I

132, Mettupalayam Road,
Perianaickenpalayam,
Coimbatore – 641 020, India.

Plant III

4/558, Mettupalayam Road,
Chinnamathampalayam,
Billichi Village, Press Colony Post,
Coimbatore – 641 019, India.

Plant VI

Plot No.11, Sector 10,
Integrated Industrial Estate,
Pantnagar, SIDCUL,
Rudrapur – 263 153, India.

Plant II

Plot No.34 & 35, Sector 4,
IMT Manesar,
Gurugram – 122 050, India.

Plant V

Gat No.180-187
Global Raison, Industrial Park,
Alandi-Markal Road, Phulgaon,
Tal-Haveli, Pune – 412216, India.

Plant VII

Plot No.45, Sector 11,
Integrated Industrial Estate,
Pantnagar, SIDCUL,
Rudrapur – 263 153, India.

t. **Address for correspondence:**

Registrar & Transfer Agents

M/s. Integrated Registry Management Services (P) Limited

Unit: Pricol Limited,
2nd Floor, “ Kences Towers ”,
No.1, Ramakrishna Street, North Usman Road,
T. Nagar, Chennai - 600 017, India.
Phone : + 91 44 28140801 - 03
Fax : + 91 44 28142479
Email : srirams@integratedindia.in

Company

Secretarial Department

Pricol Limited,

109, Race Course,
Coimbatore - 641 018, India.

Phone : + 91 422 4336238 / 6272

Fax : + 91 422 4336299

Email : cs@pricol.co.in / investor@pricol.co.in

u. **Website address** : www.pricol.com

v. **Name of the Compliance Officer** : Mr.T.G.Thamizhanban, Company Secretary

10. DISCLOSURES:

a. The Company has not entered into any materially significant related party transactions that may have potential conflict with the interest of the Company at large. Details of transactions with related parties are provided in Note No. 2.55 to Notes to Financial Statements in accordance with the provision of Accounting Standard 18. The Company has formulated a policy on related party transactions which has been placed on the website of the Company and the web link thereto is <http://www.pricol.com/Policy-on-Related-Party-Transaction.pdf>.

ANNEXURE “F” TO DIRECTORS' REPORT(Contd.,)

- b. There was no instance of non-compliance by the Company on any matters relating to the capital markets, nor was there any penalties, strictures, imposed by stock exchange(s) or SEBI or any statutory authority, on any matter related to capital markets, during the last three years.
- c. The Company has established a Vigil Mechanism / Whistle Blower Policy to enable the Stakeholders of the Company to report their genuine concerns and grievances. The Policy provides for adequate safeguards against victimization of stakeholders who avail of the vigil mechanism and direct access to the Chairman of the Audit Committee of the Company, in exceptional cases. The Protected Disclosures, if any reported under this Policy will be appropriately and expeditiously investigated by the Chairman.

The Company hereby affirms that no stakeholders including Director / employee has been denied access to the Chairman of the Audit Committee and that no complaints were received during the year. The Whistle Blower Policy has been disclosed on the website of the Company and the weblink thereto is <http://www.pricol.com/Whistle-Blower-Policy.pdf>.

- d. The Company has formulated a Policy on Subsidiary & Material Subsidiary Company and has placed it on the website of the Company and the web link thereto is <http://www.pricol.com/Pricol-Policy-on-Subsidiary&Material-Subsidiary-Company.pdf>
- e. Disclosure of commodity price risks and commodity hedging activities. Refer to Note No.2.44 to Notes to Financial Statements.
- f. The Company has complied with all the mandatory requirement of corporate governance norms as specified in Chapter IV of the SEBI (Listing Obligations and Disclosure Requirements) Regulations, 2015.
- g. The Company has complied with the following Discretionary requirements as specified in Part E of Schedule II of the SEBI (Listing Obligations and Disclosure Requirements) Regulations, 2015 :
- The Company has a non-executive Chairman who maintains a Chairman's office at the Company's expense and who is allowed reimbursement of expenses incurred in the performance of his duties.
 - Adopted the best practices to ensure a regime of financial statements with unmodified audit opinion.
 - The Company has appointed separate persons to the post of Chairman and Managing Director.

For and on behalf of the Board
Vijay Mohan
 Chairman
 (DIN : 00001843)

Coimbatore
 30th May, 2017

CODE OF CONDUCT

The Company has laid down a code of conduct for all Board members and senior management personnel. The code of conduct is available on the website of the Company under the web link <http://www.pricol.com/Code-of-Conduct-BOD&SM.pdf>. The declaration of the Managing Director is given below:

DECLARATION

All the Board members and senior management personnel affirmed compliance with the code of conduct of the Company for the financial year ended 31st March 2017.

Coimbatore
 30th May, 2017

Vikram Mohan
 Managing Director
 (DIN : 00089968)

ANNEXURE “F” TO DIRECTORS' REPORT(Contd.,)

CORPORATE GOVERNANCE COMPLIANCE CERTIFICATE

To

The Members of Pricol Limited (Formerly Pricol Pune Limited)
(CIN : L34200TZ2011PLC022194)

I have examined all the relevant records of Pricol Limited, Formerly Pricol Pune Limited ("the Company") for the purpose of certifying compliance of the conditions of corporate governance stipulated in chapter IV of SEBI (Listing Obligations and Disclosure Requirements) Regulations, 2015 for the financial year ended 31st March, 2017. I have obtained all the information and explanations which to the best of my knowledge and belief were necessary for the purpose of certification.

The compliance with the conditions of corporate governance is the responsibility of the management. My examination was limited to the procedure and implementation process adopted by the Company for ensuring compliance with the conditions of corporate governance.

This certificate is neither an assurance as to the future viability of the Company nor of the efficacy or effectiveness with which the management has conducted the affairs of the Company.

In my opinion and to the best of my information and according to the explanations given to me, I certify that the Company has complied with the conditions of corporate governance as stipulated in the aforesaid Listing Agreement & SEBI (Listing Obligations and Disclosure Requirements) Regulations, 2015.

P. Eswaramoorthy and Company

Company Secretaries

CS. P. Eswaramoorthy

Proprietor

FCS No. : 6510

C.P.No. : 7069

Coimbatore
30th May, 2017

TEN YEARS PERFORMANCE AT A GLANCE

OPERATING RESULTS

₹ Million

Year Ended 31st March	2008	2009	2010	2011	2012	2013	2014	2015	2016	2017
	Erstwhile Pricol Limited	Erstwhile Pricol Limited	Erstwhile Pricol Limited	Erstwhile Pricol Limited	Erstwhile Pricol Limited	Erstwhile Pricol Limited	Erstwhile Pricol Limited	Erstwhile Pricol Limited	Erstwhile Pricol Limited	Pricol Limited
Net Sales & Services - Domestic	4,803.69	4,765.51	6,338.06	7,100.16	7,886.74	6,996.69	6,899.65	7,842.34	9,799.21	11,305.67
- Export	1,260.94	1,375.25	1,085.86	1,062.93	1,428.05	1,285.91	1,402.78	1,162.55	1,005.28	840.96
Total Net Sales & Services	6,064.63	6,140.76	7,423.92	8,163.09	9,314.79	8,282.60	8,302.43	9,004.89	10,804.49	12,146.63
Gross Surplus from Operation	763.11	335.34	909.50	768.73	737.32	604.37	658.14	232.84	1,066.54	1,326.91
Other Income	69.41	42.28	33.30	57.15	21.47	15.16	36.22	20.06	70.00	35.67
Depreciation & Amortisation Expense (a)	327.19	364.91	351.78	337.04	291.91	319.50	306.65	352.55	341.74	659.93
Finance Costs (b)	287.00	395.51	316.45	273.12	297.92	163.31	65.20	78.90	93.12	78.27
Profit / (Loss) from operations before Exceptional Items and Tax	218.33	(382.80)	274.57	215.72	168.96	136.72	322.51	(178.55)	701.68	624.38
Exceptional Items (Net)	—	—	—	—	494.20	—	516.33	(46.77)	(100.16)	5.34
Profit / (Loss) Before Tax (PBT) (c)	218.33	(382.80)	274.57	215.72	663.16	136.72	838.84	(225.32)	601.52	629.72
Tax Provision incl. Deferred Tax	27.50	(82.56)	19.77	(15.43)	99.00	(20.68)	168.85	(45.35)	169.55	172.00
Profit / (Loss) After Tax (PAT) (d)	190.83	(300.24)	254.80	231.15	564.16	157.40	669.99	(179.97)	431.97	457.72
Dividend (including tax) (e)	63.18	—	41.98	62.76	83.68	42.12	88.45	—	114.10	114.10
Retained Profit / (Loss)	127.65	(300.24)	212.82	168.39	480.48	115.28	581.54	(179.97)	317.87	343.62
As at 31st March	2008	2009	2010	2011	2012	2013	2014	2015	2016	2017

SOURCES OF FUNDS

Share Capital	90.00	90.00	90.00	90.00	90.00	90.00	94.50	94.80	94.80	94.80
Reserves & Surplus	1,778.54	1,478.30	1,691.12	1,859.51	2,339.99	2,455.28	3,113.32	2,580.59	2,898.47	8,232.87
Money received against Share Warrants	—	—	—	—	20.25	20.25	—	—	—	—
Networth (f)	1,868.54	1,568.30	1,781.12	1,949.51	2,450.24	2,565.53	3,207.82	2,675.39	2,993.27	8,327.67
Deferred Tax Liability / (Asset)	37.19	(29.81)	(56.81)	7.00	51.00	40.00	81.00	14.00	(10.00)	368.00
Loan Funds (g)	3,250.60	3,090.05	2,559.98	2,380.60	1,738.56	1,049.24	439.42	640.10	500.00	1,083.47
Total Capital Employed (h)	5,156.33	4,628.54	4,284.29	4,337.11	4,239.80	3,654.77	3,728.24	3,329.49	3,483.27	9,779.14

APPLICATION OF FUNDS

Gross Fixed Assets	4,741.85	4,972.66	5,127.37	5,138.11	5,043.79	5,180.64	5,041.60	4,557.01	4,703.33	8,632.16
Depreciation	2,119.56	2,461.98	2,804.32	2,979.66	3,130.63	3,347.13	3,231.80	2,796.33	2,898.77	1,603.34
Net Fixed Assets	2,622.29	2,510.68	2,323.05	2,158.45	1,913.16	1,833.51	1,809.80	1,760.68	1,804.56	7,028.82
Investments	182.91	182.91	252.41	252.41	302.41	388.05	603.85	527.56	954.42	1,151.56
Net Current Assets	2,351.13	1,934.95	1,708.83	1,926.25	2,024.23	1,433.21	1,314.59	1,041.25	724.29	1,598.76
Net Assets Employed	5,156.33	4,628.54	4,284.29	4,337.11	4,239.80	3,654.77	3,728.24	3,329.49	3,483.27	9,779.14

PERFORMANCE INDICATORS

Equity Shares (Nos. in Mn) (i)	90.00	90.00	90.00	90.00	90.00	90.00	94.50	94.80	94.80	94.80
Face Value of Equity Share (₹)	1.00	1.00	1.00	1.00	1.00	1.00	1.00	1.00	1.00	1.00
Earnings per share (EPS) (₹) (d / i)	2.12	(3.34)	2.83	2.57	6.27	1.75	7.16	(1.90)	4.56	4.83
Diluted Earnings per share (₹)	2.12	(3.34)	2.83	2.57	6.18	1.67	7.16	(1.90)	4.56	4.83
Dividend per share (₹)	0.60	—	0.40	0.60	0.80	0.40	0.80	—	1.00	1.00
Networth per share (NWPS) (₹) (f / i)	20.76	17.43	19.79	21.66	27.22	28.51	33.95	28.22	31.58	87.85
Return on Average										
Networth (RONW) (%) *	10.57	(17.47)	15.21	12.39	25.65	6.28	23.21	(6.12)	15.24	5.59
Return on Average Capital										
Employed (ROCE) (%) **	10.16	0.26	13.26	11.34	22.41	7.60	24.49	(4.15)	20.39	7.72
Total Debt to Networth (g / f)	1.74	1.97	1.44	1.22	0.71	0.41	0.14	0.24	0.17	0.13
Interest Coverage Ratio (a+b+c) / b	2.90	0.95	2.98	3.02	4.21	3.79	18.57	2.61	11.13	17.48

* RONW = $\left[\frac{\text{PAT}}{\left\{ \frac{\text{Previous Year Networth} + \text{Current Year Networth}}{2} \right\}} \right] \times 100$ ** ROCE = $\left[\frac{\text{PBT} + \text{Interest}}{\left\{ \frac{\text{Previous Year Capital Employed} + \text{Current Year Capital Employed}}{2} \right\}} \right] \times 100$

REPORT OF THE INDEPENDENT AUDITOR'S TO THE SHARE HOLDERS

To the Members of Pricol Limited (Formerly Pricol Pune Limited)

Report on the Standalone Financial Statements

We have audited the accompanying standalone financial statements of **Pricol Limited (Formerly Pricol Pune Limited)** ("the Company"), which comprise the Balance Sheet as at 31st March, 2017, the Statement of Profit and Loss, the Cash Flow Statement for the year then ended and a summary of significant accounting policies and other explanatory information (hereinafter referred to as "the Standalone Financial Statements").

Management's Responsibility for the Standalone Financial Statements

The Company's Board of Directors is responsible for the matters stated in Section 134(5) of the Companies Act, 2013 ("the Act") with respect to the preparation of these standalone financial statements that give a true and fair view of the financial position, financial performance and cash flows of the Company in accordance with the accounting principles generally accepted in India, including the Accounting Standards specified under Section 133 of the Act, read with Rule 7 of the Companies (Accounts) Rules, 2014. This responsibility also includes maintenance of adequate accounting records in accordance with the provisions of the Act for safeguarding of the assets of the Company and for preventing and detecting frauds and other irregularities; selection and application of appropriate accounting policies; making judgments and estimates that are reasonable and prudent; and design, implementation and maintenance of adequate internal financial controls and ensuring their operating effectiveness and the accuracy and completeness of the accounting records, relevant to the preparation and presentation of the standalone financial statements that give a true and fair view and are free from material misstatement, whether due to fraud or error.

Auditor's Responsibility

Our responsibility is to express an opinion on these standalone financial statements based on our audit.

We have taken into account the provisions of the Act, the accounting and auditing standards and matters which are required to be included in the audit report under the provisions of the Act and the Rules made thereunder.

We conducted our audit in accordance with the Standards on Auditing specified under Section 143(10) of the Act. Those Standards require that we comply with ethical requirements and plan and perform the audit to obtain

reasonable assurance about whether the standalone financial statements are free from material misstatement.

An audit involves performing procedures to obtain audit evidence about the amounts and disclosures in the standalone financial statements. The procedures selected depend on the auditors' judgment, including the assessment of the risks of material misstatement of the standalone financial statements, whether due to fraud or error. In making those risk assessments, the auditor considers internal financial control relevant to the Company's preparation of the standalone financial statements that give a true and fair view in order to design audit procedures that are appropriate in the circumstances. An audit also includes evaluating the appropriateness of accounting policies used and the reasonableness of the accounting estimates made by the Company's Directors, as well as evaluating the overall presentation of the standalone financial statements.

We believe that the audit evidence we have obtained is sufficient and appropriate to provide a basis for our audit opinion on the standalone financial statements.

Opinion

In our opinion and to the best of our information and according to the explanations given to us, the aforesaid standalone financial statements give the information required by the Act in the manner so required and give a true and fair view in conformity with the accounting principles generally accepted in India, of the state of affairs of the Company as at 31st March, 2017, its profit and its cash flows for the year ended on that date.

Emphasis of Matter

We draw attention to Note No. 2.40 to the standalone financial statements with regard to the Scheme of Amalgamation sanctioned by the Honourable High Court of Judicature at Madras.

Our opinion is not modified in respect of this matter.

Report on Other Legal and Regulatory Requirements

- 1) As required by the Companies (Auditors' Report) Order, 2016 ("the Order") issued by the Central Government of India in terms of sub-section (11) of Section 143 of the Act, we give in "Annexure 1", a statement on the matters specified in paragraphs 3 and 4 of the Order, to the extent applicable.
- 2) As required by Section 143(3) of the Act, we report that:
 - a. We have sought and obtained all the information

REPORT OF THE INDEPENDENT AUDITOR'S TO THE SHARE HOLDERS (Contd.,)

and explanations which to the best of our knowledge and belief were necessary for the purposes of our audit;

- b. In our opinion, proper books of account as required by law have been kept by the Company so far as it appears from our examination of those books;
- c. The Balance Sheet, the Statement of Profit and Loss, and the Cash Flow Statement dealt with by this Report are in agreement with the books of account;
- d. In our opinion, the aforesaid standalone financial statements comply with the Accounting Standards specified under Section 133 of the Act read with Rule 7 of the Companies (Accounts) Rules, 2014;
- e. On the basis of written representations received from the directors as on 31st March, 2017, and taken on record by the Board of Directors, none of the directors is disqualified as on 31st March, 2017 from being appointed as a director in terms of Section 164 (2) of the Act;
- f. With respect to the adequacy of the internal financial controls over financial reporting of the Company and the operating effectiveness of such controls, we give our separate Report in "Annexure 2" ;
- g. With respect to the other matters to be included in the Auditor's Report in accordance with Rule 11 of the Companies (Audit and Auditors) Rules, 2014, in our opinion and to the best of our information and according to the explanations given to us:
 - (i) The Company has disclosed the impact of pending litigations on its financial position in

its standalone financial statements - Refer Note 2.30 on Contingent Liabilities to the standalone financial statements;

- (ii) The Company has made provision, as required under the applicable law or accounting standards, for material foreseeable losses, if any, on long-term contracts including derivative contracts - Refer Note 2.29 to the standalone financial statements ;
- (iii) There were no amounts which were required to be transferred to the Investor Education and Protection Fund by the Company ;
- (iv) The Company has provided requisite disclosures in the financial statements as to holdings as well as dealings in Specified Bank Notes during the period from 8th November, 2016 to 30th December, 2016. Based on audit procedures and relying on the management representation, we report that the disclosures are in accordance with the books of account maintained by the company and as produced to us by the Management - Refer Note 2.48 to the standalone financial statements.

For Haribhakti & Co. LLP
Chartered Accountants
ICAI Firm Registration No.103523W/W100048
Kaushik Sidartha
Partner
Membership No.: 217964

Coimbatore
30th May, 2017

★★★★★

REPORT OF THE INDEPENDENT AUDITOR'S TO THE SHARE HOLDERS (Contd.,)

ANNEXURE 1 TO THE INDEPENDENT AUDITOR'S REPORT

[Referred to in paragraph 1 under 'Report on Other Legal and Regulatory Requirements' in the Independent Auditor's Report of even date to the members of **Pricol Limited (Formerly Pricol Pune Limited)** on the standalone financial statements for the year ended 31st March, 2017]

- i) a) The Company has maintained proper records showing full particulars, including quantitative details and situation of fixed assets.
 - b) During the year, fixed assets have been physically verified by the management as per the regular programme of verification which, in our opinion, is reasonable having regard to the size of the Company and the nature of its assets. As informed, no material discrepancies were noticed on such verification.
 - c) The title deeds of immovable properties recorded as fixed assets in the books of account of the Company are held in the name of the Company.
- ii) The inventory (excluding stocks lying with third parties) has been physically verified by the management during the year. In our opinion, the frequency of verification is reasonable. As informed, no material discrepancies were noticed on physical verification carried out during the year.
- iii) As informed, the Company has not granted any loans, secured or unsecured to companies, firms, Limited Liability Partnerships or other parties covered in the register maintained under Section 189 of the Act. Accordingly, paragraph 3 (iii)(a), 3 (iii)(b) and 3 (iii)(c) of the Order are not applicable to the Company.
- iv) Based on information and explanation given to us in respect of loans, investments, guarantees and securities, the Company has complied with the provisions of Section 185 and 186 of the Act.
- v) In our opinion and according to the information and explanations given to us, the Company has not accepted any deposits from the public within the provisions of Sections 73 to 76 of the Act and the rules framed there under.
- vi) We have broadly reviewed the books of account maintained by the Company in respect of products where the maintenance of cost records has been specified by the Central Government under sub-section (1) of Section 148 of the Act and the rules framed there under and we are of the opinion that prima facie, the prescribed accounts and records have been made and maintained.
- vii) a) The Company is generally regular in depositing with appropriate authorities, undisputed statutory dues including provident fund, employees' state insurance, income tax, sales tax, service tax, value added tax, customs duty, excise duty, cess and any other material statutory dues applicable to it, however, there have been slight delay in few cases.

AND

According to the information and explanations given to us, no undisputed amounts payable in respect of provident fund, employees' state insurance, income tax, sales tax, service tax, value added tax, customs duty, excise duty, cess and any other material statutory dues applicable to it, were outstanding, at the year end, for a period of more than six months from the date they became payable.

- b) According to the information and explanation given to us, the dues outstanding with respect to, income tax, sales tax, service tax, value added tax, customs duty, excise duty on account of any dispute, are as follows :

REPORT OF THE INDEPENDENT AUDITOR'S TO THE SHARE HOLDERS (Contd.,)

Name of the statute	Nature of dues	Amount ₹ Million	Period to which the amount relates	Forum where dispute is pending	Remarks
Central Excise Act / Service Tax Act / Customs Act	i) Service Tax ii) Excise Duty iii) Service Tax iv) Customs Customs Duty Penalty v) Customs Duty vi) Excise Duty vii) Service Tax viii) Customs Duty	3.984 131.493 57.851 20.810 21.805 0.895 54.185 2.485 1.283	1999 to 2016	High Court CESTAT CESTAT CESTAT Joint Secretary - Ministry of Finance Departmental adjudication Departmental adjudication Departmental adjudication	₹ 6.643 Million has been paid under Protest
Central Sales Tax Act	i) CST Penalty ii) CST	13.325 19.988 17.760	1995-96 & 1996-97 2009-10 & 2010-11	High Court Additional Commissioner	—

viii) According to the information and explanations given to us, the Company has not defaulted in repayment of loans or borrowings to financial institution(s) and bank(s).

ix) In our opinion and according to the information and explanations given to us, the Company has not raised money by way of initial public issue offer / further public offer (including debt instruments). Money raised by way of term loans has been applied by the company for the purposes for which they were raised.

x) During the course of our examination of the books and records of the Company, carried out in accordance with the generally accepted auditing practices in India, and according to the information and explanations given to us, we have neither come across any instance of fraud by the Company or any fraud on the Company by its officers or employees, noticed or reported during the year, nor have we been informed of any such instance by the management.

xi) According to the information and explanations given to us, managerial remuneration has been paid / provided in accordance with the requisite approvals mandated by the provisions of Section 197 read with Schedule V to the Act.

xii) In our opinion and according to the information and explanations given to us, the Company is not

a Nidhi Company. Therefore, paragraph 3(xii) of the Order is not applicable to the Company.

xiii) According to the information and explanation given to us, all transactions entered into by the Company with the related parties are in compliance with Sections 177 and 188 of Act, where applicable and the details have been disclosed in the standalone financial statements etc., as required by the applicable accounting standards.

xiv) The Company has not made any preferential allotment or private placement of shares or fully or partly convertible debentures during the year under review. Therefore, paragraph 3(xiv) of the Order is not applicable to the Company.

xv) According to the information and explanations given to us, the Company has not entered into any non-cash transactions with directors or persons connected with him during the year.

xvi) According to the information and explanation given to us, the Company is not required to be registered under Section 45-IA of the Reserve Bank of India Act, 1934.

For Haribhakti & Co. LLP
Chartered Accountants

ICAI Firm Registration No.103523W/W100048

Kaushik Sidartha

Coimbatore
30th May, 2017

Partner
Membership No.: 217964

REPORT OF THE INDEPENDENT AUDITOR'S TO THE SHARE HOLDERS (Contd.,)

ANNEXURE 2 TO THE INDEPENDENT AUDITOR'S REPORT

[Referred to in paragraph 2 under 'Report on Other Legal and Regulatory Requirements' in the Independent Auditor's Report of even date to the members of **Pricol Limited (Formerly Pricol Pune Limited)** on the standalone financial statements for the year ended 31st March, 2017].

Report on the Internal Financial Controls over Financial Reporting under Clause (i) of Sub-section 3 of Section 143 of the Companies Act, 2013 ("the Act")

We have audited the internal financial controls over financial reporting of **Pricol Limited (Formerly Pricol Pune Limited)** ("the Company") as of March 31, 2017 in conjunction with our audit of the standalone financial statements of the Company for the year ended on that date.

Management's Responsibility for Internal Financial Controls

The Company's management is responsible for establishing and maintaining internal financial controls based on the internal control over financial reporting criteria established by the Company considering the essential components of internal control stated in the Guidance Note on Audit of Internal Financial Controls over Financial Reporting issued by the Institute of Chartered Accountants of India ("ICAI"). These responsibilities include the design, implementation and maintenance of adequate internal financial controls that were operating effectively for ensuring the orderly and efficient conduct of its business, including adherence to company's policies, the safeguarding of its assets, the prevention and detection of frauds and errors, the accuracy and completeness of the accounting records, and the timely preparation of reliable financial information, as required under the Companies Act, 2013.

Auditors' Responsibility

Our responsibility is to express an opinion on the Company's internal financial controls over financial reporting based on our audit. We conducted our audit

in accordance with the Guidance Note on Audit of Internal Financial Controls Over Financial Reporting (the "Guidance Note") and the Standards on Auditing specified under section 143(10) of the Act to the extent applicable to an audit of internal financial controls, both issued by the ICAI. Those Standards and the Guidance Note require that we comply with ethical requirements and plan and perform the audit to obtain reasonable assurance about whether adequate internal financial controls over financial reporting was established and maintained and if such controls operated effectively in all material respects.

Our audit involves performing procedures to obtain audit evidence about the adequacy of the internal financial controls system over financial reporting and their operating effectiveness.

Our audit of internal financial controls over financial reporting included obtaining an understanding of internal financial controls over financial reporting, assessing the risk that a material weakness exists, and testing and evaluating the design and operating effectiveness of internal control based on the assessed risk. The procedures selected depend on the auditor's judgement, including the assessment of the risks of material misstatement of the financial statements, whether due to fraud or error.

We believe that the audit evidence we have obtained is sufficient and appropriate to provide a basis for our audit opinion on the Company's internal financial controls system over financial reporting.

Meaning of Internal Financial Controls Over Financial Reporting

A company's internal financial control over financial reporting is a process designed to provide reasonable assurance regarding the reliability of financial reporting and the preparation of financial statements for external purposes in accordance with generally accepted accounting principles. A company's internal financial control over financial reporting includes those policies and procedures that (1) pertain to the maintenance of records that, in reasonable detail, accurately and fairly reflect the transactions and dispositions of the assets of the company;(2) provide

REPORT OF THE INDEPENDENT AUDITOR'S TO THE SHARE HOLDERS (Contd.,)

reasonable assurance that transactions are recorded as necessary to permit preparation of financial statements in accordance with generally accepted accounting principles, and that receipts and expenditures of the company are being made only in accordance with authorisations of management and directors of the company; and (3) provide reasonable assurance regarding prevention or timely detection of unauthorised acquisition, use, or disposition of the company's assets that could have a material effect on the financial statements.

Inherent Limitations of Internal Financial Controls Over Financial Reporting

Because of the inherent limitations of internal financial controls over financial reporting, including the possibility of collusion or improper management override of controls, material misstatements due to error or fraud may occur and not be detected. Also, projections of any evaluation of the internal financial controls over financial reporting to future periods are subject to the risk that the internal financial control over financial reporting may become inadequate because

of changes in conditions, or that the degree of compliance with the policies or procedures may deteriorate.

Opinion

In our opinion, the Company has, in all material respects, an adequate internal financial controls system over financial reporting and such internal financial controls over financial reporting were operating effectively as at 31st March, 2017, based on the internal control over financial reporting criteria established by the Company considering the essential components of internal control stated in the Guidance Note on Audit of Internal Financial Controls Over Financial Reporting issued by the ICAI.

For Haribhakti & Co. LLP
Chartered Accountants
ICAI Firm Registration No.103523W/W100048
Kaushik Sidartha
Partner
Membership No.: 217964

Coimbatore
30th May, 2017

★★★★★

BALANCE SHEET AS AT 31st MARCH 2017

	Note No.	31-3-2017 ₹ Million	31-3-2016 ₹ Million
I. EQUITY AND LIABILITIES			
(1) Shareholders' Funds			
(a) Share Capital	2.1	94.797	100.000
(b) Reserves and Surplus	2.2	8,232.867	472.930
(2) Non Current Liabilities			
(a) Long Term Borrowings	2.3	133.333	—
(b) Deferred Tax Liabilities (Net)	2.4	368.000	—
(c) Long Term Provisions	2.5	130.671	1.064
(3) Current Liabilities			
(a) Short Term Borrowings	2.6	766.808	—
(b) Trade Payables	2.7		
(i) Total Outstanding dues to Micro Enterprises and Small Enterprises		31.641	—
(ii) Total Outstanding dues to creditors other than Micro Enterprises and Small Enterprises		1,892.470	206.073
(c) Other Current Liabilities	2.8	667.376	54.811
(d) Short Term Provisions	2.9	51.598	0.097
Total		12,369.561	834.975
II. ASSETS			
(1) Non Current Assets			
(a) Fixed Assets	2.10		
(i) Property, Plant and Equipment		3,859.924	444.406
(ii) Intangible Assets		2,988.287	57.947
(iii) Capital Work-in-progress		180.610	—
(b) Non Current Investments	2.11	1,151.555	—
(c) Long Term Loans and Advances	2.12	222.191	13.986
(d) Other Non-Current Assets	2.13	455.505	9.591
(2) Current Assets			
(a) Current Investments	2.14	2.100	—
(b) Inventories	2.15	1,541.234	74.247
(c) Trade Receivables	2.16	1,725.924	210.416
(d) Cash and Cash Equivalents	2.17	72.582	12.773
(e) Short Term Loans and Advances	2.18	141.507	9.659
(f) Other Current Assets	2.19	28.142	1.950
Total		12,369.561	834.975

Significant Accounting Policies & Notes form an integral part of the Financial Statements

As per our report of even date attached
For Haribhakti & Co. LLP
Chartered Accountants
ICAI Firm Regn. No. 103523W/W100048
Kaushik Sidartha
Partner
Membership No. 217964
Coimbatore, 30th May 2017

Vijay Mohan
Chairman
(DIN : 00001843)

S. Shrinivasan
Chief Financial Officer
(ACMA No. : 17505)

For and on behalf of the Board
Vanitha Mohan
Vice Chairman
(DIN : 00002168)

Vikram Mohan
Managing Director
(DIN : 00089968)

T. G. Thamizhanban
Company Secretary
(FCS No. 7897)

STATEMENT OF PROFIT & LOSS FOR THE YEAR ENDED 31st MARCH 2017

	Note No.	2016-17 ₹ Million	2015-16 ₹ Million
INCOME			
Revenue from Operations (Gross)		13,435.094	1,369.803
Less : Excise Duty		1,288.467	153.388
Revenue from Operations (Net)	2.20	12,146.627	1,216.415
Other Operating Revenue	2.21	501.968	—
Other Income	2.22	35.671	29.310
Total Revenue		12,684.266	1,245.725
EXPENSES			
Cost of Materials Consumed	2.23	7,873.652	945.307
Purchases of Stock-in-Trade		542.377	—
Changes in inventories of Work-in-progress, Finished Goods and Stock-in-Trade	2.24	(226.519)	22.401
Employee Benefits Expense	2.25	1,713.214	112.202
Finance Costs	2.26	78.270	4.552
Depreciation and Amortisation Expense	2.27	659.933	86.480
Other Expenses	2.28	1,418.959	66.558
Total Expenses		12,059.886	1,237.500
Profit from operations before Exceptional Items and Tax		624.380	8.225
Add : Exceptional Items	2.49	5.337	82.500
Profit Before Tax		629.717	90.725
Less : Tax Expense			
Current Tax		137.000	1.300
Deferred Tax		172.000	—
MAT Credit		(137.000)	—
Profit for the year		457.717	89.425
Earnings per Equity Share (Face Value of ₹ 1/-) in Rupees	2.33		
Basic & Diluted		4.83	0.89

Significant Accounting Policies & Notes form an integral part of the Financial Statements

As per our report of even date attached
For Haribhakti & Co. LLP
Chartered Accountants
ICAI Firm Regn. No. 103523W/W100048
Kaushik Sidartha
Partner
Membership No. 217964
Coimbatore, 30th May 2017

Vijay Mohan
Chairman
(DIN : 00001843)

S. Shrinivasan
Chief Financial Officer
(ACMA No. : 17505)

For and on behalf of the Board
Vanitha Mohan
Vice Chairman
(DIN : 00002168)

Vikram Mohan
Managing Director
(DIN : 00089968)

T. G. Thamizhanban
Company Secretary
(FCS No. 7897)

CASH FLOW STATEMENT FOR THE YEAR ENDED 31st MARCH 2017

	2016-17 ₹ Million		2015-16 ₹ Million
A. CASH FLOW FROM OPERATING ACTIVITIES :			
Net Profit Before Tax	629.717		90.725
Adjustments for :			
Depreciation & Amortisation Expense	659.933	86.480	
Bad debts written off	1.679	0.583	
Provision for doubtful debts and advances written back	(2.243)	(1.243)	
Provision for doubtful debts and advances	11.574	2.243	
Provision for Diminution in Value of Current Investment written back	(0.014)	—	
(Profit) / Loss on sale of assets (Net)	(1.341)	(0.725)	
Assets Discarded / Written off	13.564	—	
Profit on Sale of Investment - Exceptional Item	(5.337)	—	
Interest received	(5.608)	(0.646)	
Exchange Fluctuation (Gain) / Loss on Re-statement	(1.834)	—	
Income from Current Investments	(0.391)	—	
Finance Costs	78.270	4.552	
	748.252		91.244
Operating Profit before working capital changes	1,377.969		181.969
Adjustments for :-			
(Increase) / Decrease in Trade and other receivables	317.251	(27.773)	
(Increase) / Decrease in Inventories	(256.629)	58.445	
Increase / (Decrease) in Trade and other payables	(423.268)	(187.113)	
	(362.646)		(156.441)
Cash generated from Operations	1,015.323		25.528
Direct taxes	(121.657)		(7.522)
Net cash from operating activities	893.666		18.006
B. CASH FLOW FROM INVESTING ACTIVITIES :			
Purchase of Fixed Assets	(831.634)	30.990	
Sale of Fixed Assets	6.580	23.856	
Purchase of Investments	(1,821.369)	—	
Sale of Investments	1,367.128	—	
Interest received	5.608	0.646	
Net Cash (used in) / from investing activities	(1,273.687)		55.492
C. CASH FLOW FROM FINANCING ACTIVITIES :			
Increase / (Decrease) in Working Capital Borrowings	566.808	(69.423)	
Increase / (Decrease) in Long Term Borrowings	(3.334)	—	
Dividend & Tax on Dividend Paid	(112.118)	—	
Finance Costs paid	(76.243)	(4.732)	
Net Cash (used in) / from financing activities	375.113		(74.155)
D. NET INCREASE / (DECREASE) IN CASH AND CASH EQUIVALENTS (A+B+C)	(4.908)		(0.657)
Cash and Bank Balances as at			
1.4.2016 and 1.4.2015 (Opening Balance)	12.773		13.430
Add : Pursuant to Scheme of Amalgamation	64.717		—
Less : Bank Balances not considered as Cash and Cash equivalents as per Accounting Standard AS 3	61.988		6.647
Cash and Cash equivalents as at 31.3.2017 and 31.3.2016 (Closing Balance) (Refer to Note No. 2.17)	10.594		6.126

Significant Accounting Policies & Notes form an integral part of the Financial Statements

As per our report of even date attached

For Haribhakti & Co. LLP

Chartered Accountants

ICAI Firm Regn. No. 103523W/W100048

Kaushik Sidartha

Partner

Membership No. 217964

Coimbatore, 30th May 2017

Vijay Mohan

Chairman

(DIN : 00001843)

S. Shrinivasan

Chief Financial Officer

(ACMA No. : 17505)

For and on behalf of the Board

Vanitha Mohan

Vice Chairman

(DIN : 00002168)

Vikram Mohan

Managing Director

(DIN : 00089968)

T. G. Thamizhanban

Company Secretary

(FCS No. 7897)

NOTES TO FINANCIAL STATEMENTS FOR THE YEAR ENDED 31st MARCH 2017

1. SIGNIFICANT ACCOUNTING POLICIES

Corporate Information:

Pricol Limited (Formerly Pricol Pune Limited) is a company incorporated on 18th May, 2011 and is engaged in the business of manufacturing and selling of Instrument clusters and other allied automobile components to Original Equipment Manufacturers (OEM) and replacement markets.

Pursuant to the Scheme of Amalgamation sanctioned by the Honourable High Court of Judicature at Madras, Erstwhile Pricol Limited (Transferor Company) amalgamated with Pricol Pune Limited (Transferee Company) with the appointed date as 1st April, 2015 and the Transferee Company was renamed from "Pricol Pune Limited" to "Pricol Limited" with effect from 18th November, 2016. The comparative figures are as per the audited financial statements of Pricol Pune Limited. Considering the above and as more specifically described in Note No. 2.40 in respect of Scheme of Amalgamation, the figures are not comparable.

I. a) Basis of preparation :

The financial statements of the Company have been prepared in accordance with the generally accepted accounting principles in India (Indian GAAP) and comply in all material respects with the accounting standards specified under section 133 of Companies act, 2013 read with Rule 7 of the Companies (Accounts) Rules, 2014. The financial statements have been prepared under the historical cost convention on an accrual basis. The accounting policies have been consistently applied by the Company and are consistent with those used in the previous year.

b) Use of estimates :

The preparation of financial statements in conformity with Generally Accepted Accounting Principles in India requires management to make estimates and assumptions that affect the reported amount of assets, liabilities, disclosures relating to contingent liabilities and assets as at the

balance sheet date and the reported amounts of income and expenses during the year. Difference between the actual amounts and the estimates are recognised in the year in which the events become known / are materialised. Although these estimates are based on the management's best knowledge of current events and actions, uncertainty about these assumptions and estimates could result in the outcomes requiring a material adjustment to the carrying amounts of assets or liabilities in future periods.

II. Property, Plant & Equipment and Depreciation :

- a) Property, Plant and Equipment (PPE), being fixed assets are tangible items that are held for use in the production or supply of goods or services, for rental to others, or for administrative purposes and are expected to be used for more than a period of twelve months. They are measured at cost less accumulated depreciation and any accumulated impairment. Cost comprises of the purchase price including import duties and non-refundable purchase taxes after deducting trade discounts and rebates and any costs attributable to bringing the asset to the location and condition necessary for it to be capable of operating in the manner intended by the Management. Own manufactured assets are capitalised at cost including an appropriate share of overheads. Financing costs relating to acquisition of assets which take substantial period of time to get ready for intended use are also included to the extent they relate to the period up to such assets are ready for their intended use.
- b) Items such as spare parts, stand-by equipment and servicing equipment are capitalised if they meet the definition of property, plant and equipment.
- c) Depreciation on Property, Plant and Equipment (PPE) are provided under straight

NOTES TO FINANCIAL STATEMENTS (Contd.,)

SIGNIFICANT ACCOUNTING POLICIES (Contd.,)

line method as per the useful lives and manner prescribed under Schedule II to the Companies Act, 2013 except for Dies, Tools & Moulds, which are depreciated over a period of 3 years and leasehold building which are amortised as depreciation over the lease period.

- d) Where the cost of a part of the PPE is significant to the total cost of the PPE and if that part of the PPE has a different useful life than the main PPE, the useful life of that part is determined separately for depreciation.
- e) The Company has used the following useful lives to provide depreciation on its Property, Plant and Equipment.

Particulars	Useful Life
Factory Buildings	: 30 years
Leasehold Buildings	: Over the period of lease
Plant & Machinery	: 7.5 years (Triple Shift)
Furniture & Fixtures	: 10 years
Vehicles	: 8 years
Office Equipments	: 5 years
Dies, Tools and Moulds	: 3 years
Computer Equipments	:-
- Servers & Networks	: 6 years
- End user devices	: 3 years

- f) The depreciation method applied to an asset is reviewed at each financial year-end and if there has been a significant change in the expected pattern of consumption of future economic benefits embodied in the asset, depreciation is charged prospectively to reflect the changed pattern.
- g) The carrying amount of an item of PPE is derecognised on disposal or when no future economic benefits are expected from its use or disposal. Gains or losses arising from derecognition of Property, Plant and equipment are measured as the difference between the net disposal proceeds and the carrying amount of the asset and are

recognized in the statement of profit and loss when the asset is de-recognised.

III. Intangible assets and amortisation :

- a) Intangible assets are recognised only if it is probable that future economic benefits that are attributable to the asset will flow to the enterprise and the cost of the asset can be measured reliably.
- b) New Product Development Cost including Technology Fee payable to Technology providers are capitalised as and when the liability gets crystallised with mutual consent of parties concerned.
- c) Computer software licenses are capitalised on the basis of costs incurred to acquire and bring to use the specific software. Operating software is capitalised and amortised along with the related fixed asset.
- d) The Company has used the following useful lives to amortise its intangible assets :

Particulars	Useful Life
Specialised software	: Over a period of 4 years
Fees for Technical Know-how	: Over a period of 4 years
Intangible Assets acquired on Amalgamation	: Over a period of 15 years based on the technical evaluation obtained by the Company (Refer to Note No. 2.40 (c))

IV. Impairment of assets :

The Company periodically assesses whether there is any indication that an asset or a group of assets comprising a cash generating unit may be impaired. If any such indication exists, the Company estimates the recoverable amount of the asset. For an asset or group of assets that does not generate largely independent cash inflows, the recoverable amount is determined for the cash-generating unit to which the asset

NOTES TO FINANCIAL STATEMENTS (Contd.,)

SIGNIFICANT ACCOUNTING POLICIES (Contd.,)

belongs. If such recoverable amount of the asset or the recoverable amount of the cash generating unit to which the asset belongs is less than its carrying amount, the carrying amount is reduced to its recoverable amount. The reduction is treated as an impairment loss and is recognised in the statement of profit and loss. If at the balance sheet date there is an indication that if a previously assessed impairment loss no longer exists, the recoverable amount is reassessed and the asset is reflected at the recoverable amount subject to a maximum of depreciable historical cost. An impairment loss is reversed only to the extent that the amount of asset does not exceed the net book value that would have been determined if no impairment loss had been recognised.

V. Investments :

- a) Long Term Investments are stated at cost.
- b) Current Investments are carried at lower of cost and fair value as on the Balance Sheet date.
- c) Provision for diminution in value of long-term investments is made, if the diminution is other than temporary.

VI. Valuation of Inventories :

- a) Inventories are valued at lower of cost and estimated net realisable value.
- b) The basis of determining cost for various categories of inventories is as follows:-
 - i) Raw Materials, Packing Materials and Stores & spares : Weighted Average Basis.
 - ii) Finished Goods and Work-in-progress : Cost of Direct Material, Labour and other Manufacturing overheads
- c) Stores & Spares which do not meet the definition of Property, Plant and Equipment are accounted as inventories.

- d) Net realisable value is the estimated selling price in the ordinary course of business, less estimated cost of completion and estimated costs necessary to make the sale.

VII. Revenue Recognition :

- a) The company generally follows the mercantile system of accounting and recognises Income and Expenditure on an accrual basis except those with significant uncertainties.
- b) Sale of goods is recognised when the risks and rewards of ownership are passed on to the customers as per the terms of contract.
- c) Dividend Income is recognised when the right to receive the dividend is unconditional at the Balance Sheet date.
- d) Interest is recognised on a time proportion basis taking into account the amount outstanding and the rate applicable.
- e) Claims made by the company including price escalations and those made on the Company are recognised in the Statement of Profit and Loss as and when the claims are accepted / liability is crystalised.

VIII. Foreign Currency Transactions :

- a) Foreign Currency Transactions are recorded in the reporting currency at exchange rates prevailing on the date of such transaction.
- b) Exchange differences arising on settlement of transactions of monetary items are recognised as income / expense in the Statement of Profit & Loss in the period in which it arises.
- c) Foreign monetary currency assets and liabilities at the year end are realigned at the exchange rate prevailing at the year end and difference on realignment is recognised in the Statement of Profit & Loss.
- d) Premium / Discount in respect of Forward Contract is amortised as expense / income

NOTES TO FINANCIAL STATEMENTS (Contd.,)

SIGNIFICANT ACCOUNTING POLICIES (Contd.,)

over the period of contract. Exchange difference arising on forward contracts between the exchange rate on the date of the transaction and the exchange rate prevailing at the year end is recognised in the Statement of Profit and Loss.

IX. Employee Benefits:

- a) Short-term employee benefits are recognised as an expense at the undiscounted amount in the Statement of Profit and Loss of the year in which the related service is rendered.
- b) Post employment and other long term benefits, which are defined benefit plans, are recognised as an expense in the Statement of Profit and Loss for the year in which the employee has rendered service. The expense is recognised based on the present value of the obligation determined as per Projected Unit Credit Method in accordance with Accounting Standard 15 on "Employee Benefits". Actuarial gains & losses are charged to the Statement of Profit and Loss.
- c) Payments to defined contribution schemes are charged as expense as and when incurred.
- d) Termination benefits are recognised as an expense, as and when incurred.

X. Borrowing Costs :

- a) Borrowing Costs attributable to the acquisition or construction of qualifying assets are capitalised as part of such assets. All other borrowing costs are charged to revenue in the period they occur.
- b) A qualifying asset is an asset that necessarily requires substantial period of time to get ready for its intended use or sale.

XI. Taxes on Income :

- a) Current tax on income for the period is determined on the basis of taxable income

and tax credits computed in accordance with the provisions of the Income Tax Act, 1961 and based on the expected outcome of assessment / appeals.

- b) Deferred tax is recognised on timing differences between the accounting income and the taxable income for the year, and quantified using the tax rates and laws enacted or substantively enacted as on the Balance Sheet date.
- c) Deferred tax assets are recognised only to the extent there is reasonable certainty that the assets can be realised in the future; however, where there is unabsorbed depreciation or carried forward business loss under taxation laws, deferred tax assets are recognised only if there is a virtual certainty of realisation of such assets.
- d) Deferred tax assets and Deferred tax liabilities are offset if a legally enforceable right exist to set off current tax assets against current tax liabilities and deferred tax assets / deferred tax liabilities relate to same taxable entity and same taxation authority.
- e) Minimum Alternate Tax (MAT) credit is recognised as an asset only when and to the extent there is convincing evidence that the company will pay normal income tax during the specified period. In the year in which the MAT credit eligible to be recognised as an asset in accordance with the recommendations contained in guidance note issued by the Institute of Chartered Accountants of India, the said asset is created by way of a credit to the statement of profit and loss and shown as MAT credit entitlement. The company reviews the same at each balance sheet date and writes down the carrying amount of MAT credit entitlement to the extent there is no longer convincing evidence to the effect that company will pay normal income tax during the specified period.

NOTES TO FINANCIAL STATEMENTS (Contd.,)

SIGNIFICANT ACCOUNTING POLICIES (Contd.,)

XII. Leases :

- a) Leases are classified as finance or operating leases depending upon the terms of the lease agreements. Assets held under finance leases are recognised as assets of the Company on the date of acquisition and depreciated over their estimated useful lives. Finance costs are treated as period cost using effective interest rate method and are expensed accordingly.
- b) Lease arrangements, where the risks and rewards incidental to the ownership of an asset substantially vest with the lessor, are recognised as an operating lease.
- c) The Assets given under operating leases are shown in Balance Sheet under Fixed Assets and depreciated on a basis consistent with the depreciation policy of the company. The lease income is recognised in the Statement of Profit and Loss on a straight line basis over the lease period.

XIII. Government Grant and Subsidies :

- a) Grants and subsidies from the Government are recognised when there is a reasonable assurance that Grant / Subsidy are received and all attached conditions complied with. Grant related to specific fixed assets are presented in the Balance Sheet by showing such Grant as deduction from the Fixed Asset concerned. Grants received in the nature of promoters contribution is credited to Capital Reserve and treated as a part of Shareholders' fund.

XIV. Earnings per Share :

- a) Basic earnings per share are calculated by dividing the net profit or loss for the period attributable to equity shareholders by the weighted average number of equity shares outstanding during the period. The weighted

average number of equity shares outstanding during the period are adjusted for events of bonus issue, bonus element in a rights issue to existing shareholders, share split and consolidation of shares, if any.

- b) For the purpose of calculating diluted earnings per share, the profit or loss for the period attributable to equity shareholders and the weighted average number of shares outstanding during the period are adjusted for the effects of all dilutive potential equity shares.

XV. Provisions and Contingencies :

- a) A provision is recognised when an enterprise has a present obligation as a result of past event and it is probable that an outflow of resources would be required to settle the obligation, in respect of which a reliable estimate can be made. Provisions are not discounted to its present value and are determined based on best estimate required to settle the obligation at the balance sheet date. These are reviewed at each balance sheet date and adjusted to reflect the current best estimates.
- b) A Contingent liability is a possible obligation that arises from past events whose existence will be confirmed by the occurrence or non-occurrence of one or more uncertain future events beyond the control of the company or a present obligation that is not recognised because it is not probable that an outflow of resources will be required to settle the obligation. A contingent liability also arises in extremely rare cases where there is a liability that cannot be recognised because it cannot be measured reliably. The company does not recognise a contingent liability but discloses its existence in the financial statements.

NOTES TO FINANCIAL STATEMENTS (Contd.,)

SIGNIFICANT ACCOUNTING POLICIES (Contd.,)

- c) Contingent Assets are neither accounted for nor disclosed

The cash flow comprises regular revenue generating, investing and financing activities of the company. Cash and cash equivalents in the balance sheet comprise of cash at bank and in hand and short term, highly liquid investments with an original maturity of three months or less, that are readily convertible into known amounts of cash and which are subject to an insignificant risk of changes in value.

XVI. Cash and Cash equivalents :

- a) Cash flow is reported using the indirect method, whereby net profit / loss before tax is adjusted for the effects of transaction of a non cash nature and any deferrals or accruals of past or future cash receipts or payments.

2.1. SHARE CAPITAL	31-3-2017	31-3-2016
	₹ Million	₹ Million
Authorised		
582,000,000 Equity Shares of ₹ 1/- each *	582.000	100.000
(Previous year - 100,000,000 Equity Shares of ₹ 1/- each)		
Issued, Subscribed and Paid-up		
94,796,721 Equity Shares of ₹ 1/- each	94.797	100.000
(Previous year - 100,000,000 Equity Shares of ₹ 1/- each)		
* Pursuant to the Scheme of Amalgamation, the Authorised Share Capital of the Company stands increased to ₹ 582 Million from ₹ 100 Million. (Refer to Note No. 2.40)		

Reconciliation of the Shares Outstanding at the beginning and at the end of the reporting period :

Equity Shares	31-3-2017		31-3-2016	
	No. of Shares Million	₹ Million	No. of Shares Million	₹ Million
At the beginning of the period	100.000	100.000	100.000	100.000
Add : Shares allotted pursuant to Scheme of Amalgamation (Refer to Note No. 2.40)	94.797	94.797	—	—
Less : Shares cancelled pursuant to Scheme of Amalgamation (Refer to Note No. 2.40)	100.000	100.000	—	—
At the closing of the period	94.797	94.797	100.000	100.000

Terms / rights attached to equity shares :

The company has only one class of equity shares having a par value of ₹ 1/- per share. Each holder of equity shares is entitled to one vote per share. The company declares and pays dividend in Indian Rupees. The dividend proposed by the Board of Directors, if any, is subject to the approval of the shareholders in the ensuing Annual General Meeting. In the event of liquidation of the Company, the holders of the equity shares will be entitled to receive remaining assets of the company, after distribution of all preferential amount. The distribution will be in proportion to the number of equity shares held by the shareholders.

NOTES TO FINANCIAL STATEMENTS (Contd.,)

SHARE CAPITAL (Contd.,)

Details of Shareholders holding more than 5% shares in the company :

	31-3-2017		31-3-2016	
	No. of Shares	% held	No. of Shares	% held
Equity Shares of ₹ 1/- each fully paid				
- Erstwhile Pricol Limited, India (Holding Company)	—	—	100,000,000	100.00%
- Vijay Mohan	9,801,178	10.34%	—	—
- Pricol Holdings Limited	8,556,926	9.03%	—	—
- Viren Mohan	6,658,409	7.02%	—	—

Details of Shares held by Holding Company :

There are no Shares held by Holding Company / Subsidiaries of ultimate Holding Company as on 31st March 2017.

Details of Shares issued for consideration other than in cash :

94,796,721 shares of ₹ 1/- each were allotted for consideration other than cash during the current financial year in terms of the Scheme of Amalgamation with Erstwhile Pricol Limited which was sanctioned by the Hon'ble High Court of Judicature at Madras on 6th October 2016.

During the year 2011-12, 4,950,000 Equity Shares of ₹ 10/- each were allotted as fully paid-up pursuant to contract without payments being received in cash. During the year 2015-16, Erstwhile Pricol Limited acquired 5,000,000 Equity Shares of ₹ 10/- each from Johnson Control Enterprise Limited, UK. These shares were subsequently cancelled pursuant to Scheme of Amalgamation.

There were no shares allotted by way of Bonus Shares and there have been no shares bought back in the immediately preceding five years.

2.2. RESERVES & SURPLUS

	31-3-2017 ₹ Million	31-3-2016 ₹ Million
Securities Premium Reserve		
Opening Balance	684.000	684.000
Add : Pursuant to Scheme of Amalgamation (Refer to Note No. 2.40)	7,412.156	—
	8,096.156	684.000
Surplus / (Deficit) in the Statement of Profit & Loss		
Opening Balance	(211.070)	(300.495)
Add : Pursuant to Scheme of Amalgamation (Refer to Note No. 2.40)	(109.936)	—
Add : Profit for the year	457.717	89.425
	136.711	(211.070)
	8,232.867	472.930

2.3. LONG TERM BORROWINGS

	Non-Current Portion		Current Maturities	
	31-3-2017 ₹ Million	31-3-2016 ₹ Million	31-3-2017 ₹ Million	31-3-2016 ₹ Million
Secured Loans :				
Rupee Term Loan From Banks	133.333	—	183.333	20.000
	133.333	—	183.333	20.000

NOTES TO FINANCIAL STATEMENTS (Contd.,)

LONG TERM BORROWINGS (Contd.,)

Term loan from Indian bank is secured by way of hypothecation of machineries and other fixed assets of the Company. The rate of interest is 14.20% and the loan was repayable in four quarterly instalments after an initial holiday period of 2 years from the date of first availment. Interest to be serviced as and when charged. The above loan has been preclosed during the year 2016-17. Hence there is no outstanding as on 31st March 2017 (Previous year - ₹ 20 Million).

Term Loan of ₹ 300 Million for Medium Term Working Capital from Bank of Bahrain and Kuwait B.S.C. is repayable in 12 quarterly instalments of ₹ 25 Million each. Interest is payable on monthly basis at the rate of Bank Base Rate plus 0.10%. The loan is secured by pari-passu first charge on the specific land and building of Plant III situated at Billichi Village, Coimbatore District. Present Outstanding as on 31st March, 2017 is ₹ 50 Million.

Term Loan of ₹ 200 Million from HDFC Bank is repayable in 12 quarterly instalments of ₹ 16.667 Million each. Interest is payable on monthly basis at the rate of Bank Base Rate plus 0.50%. The loan is secured by pari-passu first charge by hypothecation of specific plant and machinery and pari-passu first charge by way of mortgage of immovable property situated at IMT Manesar, Gurugram. Present Outstanding as on 31st March, 2017 is ₹ 83.333 Million.

Term Loan of ₹ 200 Million from Federal Bank is repayable in 12 quarterly instalments of ₹ 16.667 Million each. Interest is payable on monthly basis at the rate of Bank Base Rate plus 0.10%. The loan is secured by Equitable mortgage of immovable property on pari-passu first charge basis and hypothecation of specific Plant & Machinery on pari-passu first charge basis with HDFC Bank. Present Outstanding as on 31st March, 2017 is ₹ 183.333 Million.

2.4. DEFERRED TAX LIABILITIES - NET

		31-3-2017 ₹ Million	Charged / (Reversed) during the year ₹ Million	31-3-2016 ₹ Million
Deferred Tax Liability				
Fixed Assets		429.000	429.000	—
	A	<u>429.000</u>	<u>429.000</u>	<u>—</u>
Deferred Tax Asset				
Expenditure disallowed for tax purposes but allowable in subsequent years		61.000	61.000	—
	B	<u>61.000</u>	<u>61.000</u>	<u>—</u>
Deferred Tax Liabilities - Net	A - B	<u>368.000</u>	<u>368.000</u>	<u>—</u>
Less : Pursuant to Scheme of Amalgamation	C		<u>196.000</u>	
	A - B - C		<u>172.000</u>	

2.5. LONG TERM PROVISIONS

For Employee Benefits :

- Gratuity (Refer to Note No. 2.42 (a))	21.384	—
- Leave Encashment	—	0.676
For Central Excise Demands (Refer to Note No. 2.29)	69.158	—
For Potential Statutory Liabilities (Refer to Note No. 2.29)	40.129	0.388
	<u>130.671</u>	<u>1.064</u>

NOTES TO FINANCIAL STATEMENTS (Contd.,)

	31-3-2017 ₹ Million	31-3-2016 ₹ Million
2.6. SHORT TERM BORROWINGS		
Secured Loans		
Working Capital Facilities from Banks		
- In Rupee	566.808	—
Unsecured Loans		
Working Capital Facilities from Banks		
- In Rupee	200.000	—
	<u>766.808</u>	<u>—</u>

Working Capital Facilities from State Bank of India, ICICI Bank, Axis Bank and HDFC Bank are secured by pari-passu first charge on the current assets of the company. Working Capital Facilities are further secured by pari-passu second charge on the specific immovable properties situated at Plant I - Perianaickenpalayam, Coimbatore District, Tamilnadu.

Working Capital Facilities from Bank of Bahrain and Kuwait B.S.C. is secured by pari-passu first charge on the specific land and building of Plant III situated at Billichchi Village, Coimbatore District.

Working Capital Facilities from Banks are repayable on demand and carries interest rates varying from 9.65% to 11.10% p.a.

2.7. TRADE PAYABLES

- Total Outstanding Dues to Micro Enterprises and Small Enterprises (Refer to Note No. 2.50)	31.641	—
- Total Outstanding Dues to creditors other than Micro Enterprises and Small Enterprises	1,892.470	206.073
	<u>1,924.111</u>	<u>206.073</u>

There are no interest amounts paid / payable to Micro Enterprises and Small Enterprises. The information in relation to dues to Micro Enterprises and Small Enterprises have been determined to the extent such parties have been identified on the basis of information available with the Company, which has been relied upon by the auditors.

2.8. OTHER CURRENT LIABILITIES

Current Maturities of Long Term Debt (Refer to Note No. 2.3)	183.333	20.000
Interest accrued and not due on borrowings	5.037	0.199
Unclaimed Dividend	7.123	—
Statutory Dues Payable	43.393	9.580
Employee Benefits Payable	253.248	5.268
Other Payables *	175.242	19.764
	<u>667.376</u>	<u>54.811</u>

* Other Payables includes accrued expenses and Rental Deposit Received

2.9. SHORT TERM PROVISIONS

For Employee Benefits :		
- Gratuity (Refer to Note No. 2.42 (a))	15.004	—
- Leave Encashment	—	0.097
For Labour Settlement (Refer to Note No. 2.29)	26.172	—
For Taxation	10.422	—
	<u>51.598</u>	<u>0.097</u>

2.10. FIXED ASSETS

₹ Million

	Gross Block				Depreciation / Amortisation				Net Block				
	Cost as on 1-4-2016	Additions during 2016-17	Assets acquired on Amalgamation	Adjustments on Amalgamation (Net) #	Sales / Deletions during 2016-17	Balance as on 31-3-2017	Upto 31-3-2016	For 2016-17	Adjustments on Amalgamation (Net) #	Withdrawn during 2016-17	Total upto 31-3-2017	Written down Value as on 31-3-2016	Written down Value as on 31-3-2017
Property, Plant and Equipment													
Land :													
Freehold Land	195.064	—	903.138	2.322	2.200	1,098.324	—	—	—	—	—	195.064	1,098.324
Leasehold Land	—	—	76.100	—	—	76.100	—	0.789	0.271	—	1.060	—	75.040
Buildings :													
Freehold Buildings	165.959	58.791	1,252.767	2.030	0.193	1,479.354	21.755	75.365	69.914	0.014	167.020	144.204	1,312.334
Leasehold Buildings	—	24.870	4.033	—	—	28.903	—	1.691	1.344	—	3.035	—	25.868
Plant & Machinery	183.022	522.540	701.522	245.732	27.823	1,624.993	82.171	223.498	189.380	12.750	482.299	100.851	1,142.694
Furniture and Fixtures	1.791	29.032	28.289	2.399	1.536	59.975	0.635	5.115	4.318	0.440	9.628	1.156	50.347
Vehicles	1.033	2.116	11.649	12.388	0.143	27.043	0.066	3.662	2.249	0.111	5.866	0.967	21.177
Office Equipments	2.937	0.226	3.046	0.002	0.182	6.029	0.830	1.247	0.723	0.133	2.667	2.107	3.362
Computer Equipments	1.160	56.573	108.815	33.276	0.517	199.307	1.103	34.390	33.381	0.345	68.529	0.057	130.778
Total Property, Plant and Equipment	550.966	694.148	3,089.359	298.149	32.594	4,600.028	106.560	345.757	301.580	13.793	740.104	444.406	3,859.924
Intangible Assets													
Computer Software	0.683	21.384	73.281	11.188	0.038	106.498	0.603	29.080	30.465	0.036	60.112	0.080	46.386
Technical Knowhow	—	—	2.775	48.307	—	51.082	—	1.022	48.845	—	49.867	—	1.215
Brand / Trade Mark	—	—	491.400	—	—	491.400	—	32.760	32.760	—	65.520	—	425.880
Patents & Developed Technology	—	—	1,411.600	—	—	1,411.600	—	94.107	94.107	—	188.214	—	1,223.386
Goodwill \$	300.845	—	1,490.100	—	—	1,790.945	242.978	157.207	99.340	—	499.525	57.867	1,291.420
Total Intangible Assets	301.528	21.384	3,469.156	59.495	0.038	3,851.525	243.581	314.176	305.517	0.036	863.238	57.947	2,988.287
Total	852.494	715.532	6,558.515	357.644	32.632	8,451.553	350.141	659.933	607.097	13.829	1,603.342	502.353	6,848.211
Capital Work-in-progress													180.610

Adjustments on Amalgamation represents changes in Gross Block / Accumulated depreciation in the books of Erstwhile Pricol Limited post the appointed date. (Refer to Note No. 2.40.)

\$ Additions to Goodwill represents Customer Relationships and Assembled Workforce acquired consequent to Amalgamation. (Refer to Note No. 2.40.)

Note : Freehold Land includes ₹ 49,988 Million paid by the company towards the claim for additional compensation by Haryana State Industrial and Infrastructure Development Corporation Limited (HSIIDC). The claim by HSIIDC is made in instalments and the payment is made as and when the instalments become due. The said payment had been made under protest and the matter is pending before the Supreme Court. Pending disposal of the appeal by the Court, the payment of instalments are capitalised to the cost of the land.

**FIXED ASSETS (Contd.,)
COMPARATIVES :**

₹ Million

	Gross Block			Depreciation / Amortisation			Net Block			
	Cost as on 1-4-2015	Additions during 2015-16	Sales / Deletions during 2015-16	Balance as on 31-3-2016	Upto 31-3-2015	For 2015-16	Withdrawn during 2015-16	Total upto 31-3-2016	Written down Value as on 31-3-2016	as on 31-3-2015
Property, Plant and Equipment										
Land :										
Freehold Land	195.064	—	—	195.064	—	—	—	—	195.064	195.064
Buildings :										
Freehold Buildings	165.959	—	—	165.959	16.521	5.234	—	21.755	144.204	149.438
Plant & Machinery	206.855	5.292	29.125	183.022	68.363	19.817	6.009	82.171	100.851	138.492
Furniture and Fixtures	1.791	—	—	1.791	0.474	0.161	—	0.635	1.156	1.317
Vehicles	—	1.033	—	1.033	—	0.066	—	0.066	0.967	—
Office Equipments	0.902	2.053	0.018	2.937	0.273	0.560	0.003	0.830	2.107	0.629
Computer Equipments	1.160	—	—	1.160	0.801	0.302	—	1.103	0.057	0.359
Total Property, Plant and Equipment	571.731	8.378	29.143	550.966	86.432	26.140	6.012	106.560	444.406	485.299
Intangible Assets										
Computer Software	0.683	—	—	0.683	0.432	0.171	—	0.603	0.080	0.251
Goodwill	300.845	—	—	300.845	182.809	60.169	—	242.978	57.867	118.036
Total Intangible Assets	301.528	—	—	301.528	183.241	60.340	—	243.581	57.947	118.287
Total	873.259	8.378	29.143	852.494	269.673	86.480	6.012	350.141	502.353	603.586

NOTES TO FINANCIAL STATEMENTS (Contd.,)

	31-3-2017 ₹ Million	31-3-2016 ₹ Million
2.11. NON CURRENT INVESTMENTS		
1. Shares in Subsidiary Company - Non Trade - Unquoted :		
a) 8,884,790 Equity Shares of Euro 1/- each fully paid-up in Pricol Espana S.L. Spain - (Extent of holding - 100%)	684.365	—
2. Shares in Subsidiary Company - Trade - Unquoted :		
a) 7,500 Equity Shares of USD 1,000/- each fully paid-up in PT Pricol Surya Indonesia - (Extent of holding - 100%)	452.152	—
b) 250,000 Equity Shares of USD 1/- each fully paid-up in Pricol Asia Pte Limited, Singapore - (Extent of holding - 100%)	15.038	—
Aggregate Cost of Un-Quoted Investments	1,151.555	—

2.12. LONG TERM LOANS AND ADVANCES

Unsecured Considered Good

Capital Advances	165.451	1.208
Deposits with Custom Authorities	7.399	7.399
Other Deposits #	49.341	5.379

Unsecured Considered Doubtful

Other Deposits #	2.610	—
Less : Provision for Doubtful Deposits	2.610	—
	<u>—</u>	<u>—</u>
	222.191	13.986

Other Deposits include Rental & Security Deposits

2.13. OTHER NON-CURRENT ASSETS

Unsecured Considered Good

Loans to Employees	0.046	—
Balances with Government Authorities	1.209	—
Advance Tax, Net off Provision	79.584	9.591
MAT Credit Entitlement	374.666	—
	<u>455.505</u>	<u>9.591</u>

2.14. CURRENT INVESTMENTS

S. No.	Particulars	Amount (₹ Million)		Market Value (₹ Million)	
		31-3-2017	31-3-2016	31-3-2017	31-3-2016
Investments in Mutual Funds - Non Trade - Quoted - Fully paid - Valued at Lower of Cost and Net Realisable Value					
1.	ICICI Prudential MIP - 25 - Growth - Regular Plan	0.700	—	0.836	—
2.	IDFC Asset Allocation Fund of Funds - Aggressive Plan - Growth - Regular Plan	0.700	—	0.807	—
3.	Birla Sun Life MIP II - Wealth 25 Plan - Growth - Regular Plan	0.700	—	0.865	—
	Aggregate Cost / Market Value of Quoted Investments	2.100	—	2.508	—

NOTES TO FINANCIAL STATEMENTS (Contd.,)

	31-3-2017 ₹ Million	31-3-2016 ₹ Million
2.15. INVENTORIES		
(Valued at Lower of Cost and Net Realisable Value)		
Raw Materials & Components (includes Goods in Transit of ₹ 130.865 Million Previous year - ₹ 6.768 Million)	874.443	61.259
Work-in-progress	94.580	9.772
Finished Goods	371.157	3.216
Land - Stock-in-Trade	141.900	—
Stores & Spares	31.467	—
Traded Goods	27.687	—
	<u>1,541.234</u>	<u>74.247</u>
2.16. TRADE RECEIVABLES		
a) Outstanding for a period exceeding six months from the date they are due for payment		
i) Unsecured Considered Good	—	—
ii) Unsecured Considered Doubtful	101.490	0.729
Less : Provision for Doubtful Debts	<u>101.490</u>	<u>0.729</u>
b) Outstanding for a period less than six months from the date they are due for payment		
i) Unsecured Considered Good	1,725.924	210.416
ii) Unsecured Considered Doubtful	1.439	1.514
Less : Provision for Doubtful Debts	<u>1.439</u>	<u>1.514</u>
	<u>1,725.924</u>	<u>210.416</u>
2.17. CASH AND CASH EQUIVALENTS		
Balances with Banks		
In Current Account	9.193	6.317
In Unclaimed Dividend Account	7.123	—
In Fixed Deposit Account	42.904	—
In Margin Money Account #	11.961	6.429
Cash on hand	<u>1.401</u>	<u>0.027</u>
	<u>72.582</u>	<u>12.773</u>
# Margin Money with banks is towards issue of Letter of Comfort, Letter of Credit, Buyers Credit for Imports and Bank Guarantee.		
Of the above, the balances that meet the definition of Cash and Cash equivalent as per AS 3 Cash Flow Statement is	<u>10.594</u>	<u>6.126</u>

NOTES TO FINANCIAL STATEMENTS (Contd.,)

	31-3-2017 ₹ Million	31-3-2016 ₹ Million
2.18. SHORT TERM LOANS AND ADVANCES		
Unsecured Considered Good		
Advances to Employees	2.391	0.005
Advances to Suppliers #	54.580	1.653
Balances with Government Authorities	84.536	8.001
Unsecured Considered Doubtful		
Advances to Suppliers #	1.133	—
Less : Provision for Doubtful Advances	1.133	—
	<u>—</u>	<u>—</u>
	141.507	9.659
2.19. OTHER CURRENT ASSETS		
Unsecured Considered Good		
Accrued Income	3.284	0.119
Prepaid Expenses	24.858	1.208
Gratuity Fund	—	0.623
	<u>—</u>	<u>—</u>
	28.142	1.950
2.20. REVENUE FROM OPERATIONS		
Sale of Products and Services	2016-17 ₹ Million	2015-16 ₹ Million
Domestic	12,448.779	1,357.156
Export	840.961	12.647
Traded Goods	104.695	—
Service Income	40.659	—
	<u>13,435.094</u>	<u>1,369.803</u>
Less : Excise Duty	1,288.467	153.388
	<u>12,146.627</u>	<u>1,216.415</u>
Details of Sale of Products and Services :		
1. Dashboard Instruments & Accessories		
a) Dashboard Instruments	4,671.459	1,216.415
b) Speedometer Cables	12.416	—
c) Sensors	1,300.446	—
d) Accessories & Sub-assembly Components	318.024	—
2. Oil Pumps	1,112.166	—
3. Chain Tensioners	448.347	—
4. Idle Speed Control Valve Assembly	68.935	—
5. Other Auto Components	407.709	—
6. Road Speed Limiter	1,886.453	—
7. Other Products & Service Income	1,920.672	—
	<u>12,146.627</u>	<u>1,216.415</u>

NOTES TO FINANCIAL STATEMENTS (Contd.,)

	2016-17 ₹ Million	2015-16 ₹ Million
2.21. OTHER OPERATING REVENUE		
Export Incentives	10.253	—
Sale of Traded Goods - Others	491.715	—
	<u>501.968</u>	<u>—</u>
2.22. OTHER INCOME		
Interest Received	5.608	0.646
Income from Current Investments	0.391	—
Rent Received	21.694	4.620
Profit on Sale of Assets (Net)	1.341	0.725
Miscellaneous Income / Unclaimed Credits written back	4.277	6.300
Excess Provision No Longer required written back	2.346	17.019
Provision for Diminution in Value of Current Investments written back	0.014	—
	<u>35.671</u>	<u>29.310</u>
2.23. COST OF MATERIALS CONSUMED		
Materials Consumed (Refer to Note No. 2.38)	<u>7,873.652</u>	<u>945.307</u>
2.24. CHANGES IN INVENTORIES OF WORK-IN-PROGRESS, FINISHED GOODS AND STOCK-IN-TRADE		
Opening Stock		
Work-in-progress	9.772	21.494
Finished Goods	3.216	13.895
Traded Goods	—	—
Land - Stock-in-Trade	—	—
	<u>12.988</u>	<u>35.389</u>
Add : Inventory Acquired on Amalgamation		
Work-in-progress	84.691	—
Finished Goods	140.108	—
Traded Goods	29.118	—
Land - Stock-in-Trade	141.900	—
	<u>395.817</u>	<u>—</u>
Less : Closing Stock		
Work-in-progress	94.580	9.772
Finished Goods	371.157	3.216
Traded Goods	27.687	—
Land - Stock-in-Trade	141.900	—
	<u>635.324</u>	<u>12.988</u>
	<u>(226.519)</u>	<u>22.401</u>

NOTES TO FINANCIAL STATEMENTS (Contd.,)

	2016-17 ₹ Million	2015-16 ₹ Million
2.25. EMPLOYEE BENEFITS EXPENSE		
a) Pay, Allowances and Bonus	1,467.466	100.660
b) Contribution to Provident and other funds	109.650	2.078
c) Welfare Expenses	136.098	9.464
	<u>1,713.214</u>	<u>112.202</u>
2.26. FINANCE COSTS		
Interest on Loans	71.983	4.552
Other Borrowing Costs	1.258	—
Exchange differences to the Extent considered as an adjustment to borrowing cost	5.029	—
	<u>78.270</u>	<u>4.552</u>
2.27. DEPRECIATION AND AMORTISATION EXPENSE		
Depreciation (Refer to Note No. 2.10)	345.757	26.140
Amortisation of Intangibles (Refer to Note No. 2.10)	314.176	60.340
	<u>659.933</u>	<u>86.480</u>
2.28. OTHER EXPENSES		
Power & Utilities (Refer to Note No. 2.34)	181.040	8.550
Stores & Spares Consumed	8.467	—
Repairs and Maintenance :		
- Machinery	144.995	2.217
- Building	58.848	—
- Others	24.125	5.148
Printing & Stationery	11.657	0.634
Postage & Telephone	20.974	0.559
Rent	35.503	—
Rates, Taxes & Licence	22.695	1.609
Insurance	27.531	0.599
Bank Charges	8.798	3.211
Travelling & Conveyance	125.189	1.273
Freight & Forwarding and Selling Expenses	228.503	19.662
Advertisement & Sales Promotion	18.352	0.009
Commission & Discount on Sales	39.822	—
Royalty	7.284	—
Bad Debts Written off	1.679	0.583
Provision for doubtful debts and advances	11.574	2.243
Less : Provision for Doubtful debts and advances written back	2.243	1.243
	<u>9.331</u>	<u>1.000</u>
Provision for Statutory Liabilities	—	0.388
Commission / Sitting Fees to Non-Whole Time Directors	3.494	0.004
Auditors' Remuneration (Refer to Note No. 2.36)	5.580	0.650
Professional Charges	376.971	8.085
Loss on Exchange Fluctuation (Net)	16.965	3.528

NOTES TO FINANCIAL STATEMENTS (Contd.,)

	2016-17 ₹ Million	2015-16 ₹ Million
OTHER EXPENSES (Contd.,)		
Assets Discarded / Written Off	13.564	5.784
Miscellaneous Expenses	20.627	3.060
CSR Expenses (Refer to Note No. 2.47)	3.950	—
Donations	3.015	0.005
	<u>1,418.959</u>	<u>66.558</u>

2.29. PROVISIONS AS ON THE CLOSING DATE :

	₹ Million			
	Opening Balance 1-4-2016	Addition / Adjustment on Amalgamation	Utilised / Reversed	Closing Balance 31-3-2017
Long Term Provisions :				
Excise Demands	—	69.158	—	69.158
Potential Statutory Liabilities	0.388	42.087	2.346	40.129
Total Long Term Provisions	0.388	111.245	2.346	109.287
Short Term Provisions :				
Labour Settlement	—	27.502	1.330	26.172
Total Provisions	0.388	138.747	3.676	135.459

2.30. CONTINGENT LIABILITIES AND COMMITMENTS AS ON THE CLOSING DATE :

CONTINGENT LIABILITIES

a) On account of Pending Litigations :

	As at 31-3-2017 ₹ Million	As at 31-3-2016 ₹ Million
Sales Tax Matters (excluding Interest if any)	51.073	—
Excise, Service Tax and Customs Matters (excluding Interest & Penalty if any)	225.633	42.615

b) Others :

	As at 31-3-2017 ₹ Million	As at 31-3-2016 ₹ Million
Corporate Guarantee to Subsidiaries @	630.000	—
Letter of Credit	133.456	—
	<u>1,040.162</u>	<u>42.615</u>

COMMITMENTS

	As at 31-3-2017 ₹ Million	As at 31-3-2016 ₹ Million
Estimated Value of Contracts remaining to be executed on Capital account	117.702	1.174

@ Details of Corporate Guarantee given to Subsidiaries :

S. No.	Name of the Subsidiary	Purpose	As at 31-3-2017 ₹ Million	As at 31-3-2016 ₹ Million
1.	Pricol do Brasil Componentes Automotivos Ltda, Brazil	Term Loan / Working Capital	420.000	—
2.	PT Pricol Surya Indonesia	Term Loan / Working Capital	210.000	—
	Total		<u>630.000</u>	<u>—</u>

NOTES TO FINANCIAL STATEMENTS (Contd.,)

	2016-17 ₹ Million	2015-16 ₹ Million
2.31. EARNINGS IN FOREIGN CURRENCY (FOB) :		
Exports Sales	<u>812.865</u>	<u>12.549</u>
2.32. EXPENDITURE IN FOREIGN CURRENCY :		
<u>CIF Value of Imports :</u>		
Raw Materials & Components	2,039.812	387.965
Spares	6.312	—
Capital Goods	<u>168.859</u>	<u>—</u>
	<u>2,214.983</u>	<u>387.965</u>
<u>Other Payments :</u>		
Royalty on Sales	7.284	—
Overseas Office Expenses	40.306	—
Export Sales Commission to Agents	11.716	—
Professional Services received	9.624	—
Interest on Buyers Credit	<u>3.459</u>	<u>—</u>
	<u>72.389</u>	<u>—</u>
2.33. EARNINGS PER SHARE		
Profit After Tax	457.717	89.425
Weighted Average No. of Shares Outstanding		
Basic and Diluted (Nos. in Mn.)	94.797	100.000
Basic and Diluted Earnings per share (in ₹)	4.83	0.89
Face Value per Equity Share (in ₹)	1.00	1.00
2.34. Power & Utilities is net of Wind Power of ₹ 9.885 Million (Previous year - ₹ Nil) representing power supplied to the grid against which equivalent consumption was made in house.		
2.35. RESEARCH AND DEVELOPMENT EXPENDITURE :		
Capital	32.294	—
Recurring	<u>350.569</u>	<u>—</u>
	<u>382.863</u>	<u>—</u>
Note : Research and Development expenses of Revenue nature have been classified under the relevant heads of accounts in the Statement of Profit and Loss and the expenditure of capital nature is grouped under fixed assets.		
2.36. REMUNERATION TO AUDITORS (EXCLUSIVE OF SERVICE TAX) :		
For Audit	3.500	0.650
For Taxation Matters	0.942	—
For Certification & Others	0.959	—
Reimbursement of Expenses	<u>0.179</u>	<u>—</u>
	<u>5.580</u>	<u>0.650</u>

NOTES TO FINANCIAL STATEMENTS (Contd.,)

2.37. Balances in parties accounts are subject to confirmation / reconciliation. Appropriate adjustments, if any, will be made as and when the balances are reconciled.

2.38. COST OF MATERIALS CONSUMED :

Value of imported and indigenous Raw Materials Consumed :

	2016-17		2015-16	
	₹ Million	%	₹ Million	%
Imported	1,651.689	20.98	392.682	41.54
Indigenous	6,221.963	79.02	552.625	58.46
	7,873.652	100.00	945.307	100.00

In view of the considerable number of items diverse in composition, size and nature, it is not practicable to furnish particulars of materials consumed.

2.39. Income Tax Assessments are completed upto Assessment Year 2014-15. The Company has preferred appeals against certain disallowances made in the assessments. In the opinion of the Company the provision for taxation available in the books of accounts is adequate.

2.40. AMALGAMATION OF ERSTWHILE PRICOL LIMITED WITH THE COMPANY :

- (a) The shareholders of Erstwhile Pricol Limited (Transferor Company) and Erstwhile Pricol Pune Limited (Transferee Company) approved the Scheme of Amalgamation ("Scheme") of Transferor Company with the appointed date as 1st April, 2015. Pricol Limited was engaged in the manufacturing, marketing, trading and export of Automotive Components and precision engineered products to Original Equipment Manufacturers and Replacement Market. The said scheme was as sanctioned by the Hon'ble High Court of Judicature at Madras on 6th October, 2016. The certified copy of the High Court sanctioning the Scheme was filed with Ministry of Corporate Affairs on 1st November, 2016 (Effective Date). The scheme has accordingly been given effect to in the financial statements. The amalgamation has been accounted for under the "Purchase Method" as prescribed under Accounting Standard 14 - "Accounting for Amalgamations" (AS 14) notified under the Companies Act 2013. Accordingly, giving effect to the Scheme of Amalgamation, all the assets (including intangible assets if any whether or not recorded in the books of Transferor Company) and liabilities of Transferor Company were recorded in the books of the Transferee Company at their respective fair values. In respect of Inter-company owings, the outstanding balance (Net) of ₹ 50.390 Million have been eliminated. Pursuant to the Scheme of Amalgamation, the Transferee Company was renamed as "Pricol Limited" vide fresh Certificate of Incorporation granted by the Ministry of Corporate Affairs on 18th November, 2016.
- (b) Upon the Scheme being effective, in consideration of the transfer and vesting of the entire undertaking of the business of the Transferor Company, the shareholders of the Transferor Company as on the Record date (6th December, 2016) have been allotted one equity share of ₹ 1 each fully paid-up of Transferee Company for every one equity share of ₹ 1 each fully paid-up in the Transferor Company. Thus, the Transferee Company has allotted 94,796,721 Equity Share of ₹ 1 each fully paid-up and the Transferee Company has accounted for Securities Premium of ₹ 7,412.156 Million representing a premium of ₹ 78.19 per equity share. The shares held by the Transferor Company in Transferee Company stands cancelled pursuant to Scheme of Amalgamation.
- (c) Intangible Assets acquired by the Transferee Company pursuant to amalgamation include :
- separately identified intangible assets like Brand / Trade Mark, Patents & Developed Technology
 - Goodwill comprising other intangible assets namely Customer Relationships and Assembled Workforce, in line with Accounting Standard - 26 (AS 26) on "Intangible Assets". Such Goodwill has been treated at par with other separately identified intangible assets and is amortised over a period of 15 years. Para 19 of

NOTES TO FINANCIAL STATEMENTS (Contd.,)

AMALGAMATION OF ERSTWHILE PRICOL LIMITED WITH THE COMPANY (Contd.,)

AS-14 considers a period of 5 years as appropriate to amortise the goodwill on amalgamation unless a longer period is justified. The company has made a technical evaluation on the useful life, which has been relied upon by the auditors, based on which the goodwill has been amortised over a period of 15 years.

Disclosure of impact on adopting a longer useful life in the financial statements :

The amortisation expense for the year would have been higher by ₹ 198.680 Million, the profit for the year would have been lower by ₹ 198.680 Million, adjustment pursuant to Scheme of Amalgamation in the opening balance of Deficit in the Statement of Profit and Loss higher by ₹ 198.680 Million and the resultant Reserves and Surplus lower by ₹ 397.360 Million.

- (d) The working results of the transferor company for the period 1st April, 2015 to 31st March, 2016 has been adjusted in the opening balance of Surplus / (Deficit) in Statement of Profit and Loss.

2.41. ASSETS AND LIABILITIES TRANSFERRED BY THE TRANSFEROR COMPANY PURSUANT TO SCHEME OF AMALGAMATION :

	₹ Million
a) Non Current Assets	7,374.112
b) Current Assets	2,999.162
c) Non Current Liabilities	326.867
d) Current Liabilities	<u>2,589.454</u>

2.42. a) PARTICULARS REGARDING DEFINED BENEFIT PLAN :

The company operates a defined benefit plan for payment of post employment benefits in the form of Gratuity. Benefits under the plan are based on pay and years of service and are vested on completion of five years of service, as provided in the Payment of Gratuity Act, 1972. The terms of the benefits are common for all the employees of the company.

I. Principal actuarial assumptions used as at the Balance Sheet Date :

Period Covered	2016-17	2015-16
Discount Rate	7.13% p.a.	7.94% p.a.
Expected Return on Plan assets	7.50% p.a.	7.94% p.a.
Average future working life	15 yrs	16 yrs

The estimates of future salary increases are considered in actuarial valuation, taking into account of inflation, seniority, promotion and other relevant factors such as supply and demand in the employment market.

II. Changes in the Present Value of the Obligation :

	₹ Million	₹ Million
Present Value of obligation at the beginning of the period (including adjustment on Amalgamation)	293.979	3.097
Interest cost	19.509	0.246
Current service cost	18.262	0.657
Past service cost	—	—
Benefits paid	(34.008)	(1.342)
Transfer of obligation due to transfer of employees to Group Entities	(6.708)	—
Actuarial (Gain) / Loss on obligation	19.667	(0.845)
Present Value of obligation at the end of the period	310.701	1.813

NOTES TO FINANCIAL STATEMENTS (Contd.,)

	2016-17 ₹ Million	2015-16 ₹ Million			
III. Changes in the Fair Value of plan assets :					
Fair Value of plan assets at the beginning of the period (including adjustment on Amalgamation)	172.407	3.069			
Expected return on plan assets	16.752	0.243			
Contributions	122.600	0.499			
Benefits paid	(31.924)	(1.342)			
Transfer of obligation due to transfer of employees to Group Entities	(6.708)	—			
Actuarial Gain / (Loss) on plan assets	1.186	(0.033)			
Fair Value of plan assets as at the end of the period	274.313	2.436			
IV. Amounts recognised in the Balance Sheet					
Present Value of obligation	310.701	1.813			
Fair Value of plan assets	(274.313)	(2.436)			
Liability / (Asset)	36.388	(0.623)			
Unrecognised past service cost	—	—			
Asset / (Liability) recognised in the Balance Sheet	(36.388)	0.623			
V. Expenses recognised in the Statement of Profit & Loss :					
Current service cost	18.262	0.657			
Interest Cost	19.509	0.246			
Expected return on plan assets	(16.752)	(0.243)			
Net Actuarial (Gain) / Loss recognised in the year	18.481	(0.812)			
Past service cost	—	—			
Expenses recognised in the Statement of Profit & Loss	39.500	(0.152)			
The expense has been included under the head "Contribution to provident and other funds" under "Employee Benefits Expense" in the Statement of Profit & Loss.					
			₹ Million		
	2016-17	2015-16	2014-15	2013-14	2012-13
VI. Amount for the current period :					
Present Value of obligation	310.701	1.813	3.097	2.370	2.930
Plan Assets	274.313	2.436	3.069	3.200	2.390
Surplus / (Deficit)	(36.388)	0.623	(0.028)	0.830	(0.540)
Experience adjustments on plan liabilities	(31.422)	(0.817)	0.190	(0.190)	—
Experience adjustments on plan assets	0.069	(0.034)	0.010	0.030	0.110
VII. Major Categories of plan assets (As percentage of total plan assets)	2016-17 ₹ Million				2015-16 ₹ Million
Funds Managed by Insurance Companies	100%				100%
VIII. Enterprise's best estimate of contribution during next year (₹ Million)	15.004				1.000
b) Contribution of ₹ 65.400 Million (Previous year - ₹ 1.986 Million) made to defined contribution plans were charged to Statement of Profit and Loss.					

NOTES TO FINANCIAL STATEMENTS (Contd.,)

	2016-17 ₹ Million	2015-16 ₹ Million
2.43. OPERATING LEASES :		
a) As Lessee		
Amortisation of premium paid for leasehold rights	0.271	—
Annual lease payments charged off to Statement of Profit and Loss	24.521	—
Future Minimum Lease Payments		
- Not later than one year	38.477	—
- Later than one year and not later than five years	137.759	—
- Later than five years	150.729	—
b) As Lessor		
Annual lease receipts included as income in the Statement of Profit and Loss	11.406	—
Future Minimum Lease Receivables		
- Not later than one year	—	—
- Later than one year and not later than five years	—	—
- Later than five years	—	—

2.44. a) DETAILS OF FOREIGN CURRENCY EXPOSURES THAT ARE HEDGED BY A DERIVATIVE INSTRUMENT OR OTHERWISE :

Particulars	Foreign Currency	2016-17	2015-16	2016-17	2015-16
		Amount of Foreign Currency in Million		Equivalent Amount in ₹ Million	
Buyers Credit	USD	3.454	—	233.450	—

b) DETAILS OF FOREIGN CURRENCY EXPOSURES THAT ARE NOT HEDGED BY A DERIVATIVE INSTRUMENT OR OTHERWISE :

Particulars	Foreign Currency	2016-17	2015-16	2016-17	2015-16
		Amount of Foreign Currency in Million		Equivalent Amount in ₹ Million	
Trade Payables	CHF	—	0.022	—	1.515
	EUR	0.011	—	0.769	—
	JPY	131.796	2.334	76.389	1.378
	USD	0.624	0.665	40.481	44.082
Trade Receivables	EUR	0.406	—	28.096	—
	USD	2.134	0.045	138.375	2.996
	GBP	0.005	—	0.402	—
Buyers Credit	USD	—	0.248	—	16.457

NOTES TO FINANCIAL STATEMENTS (Contd.,)

2.45. SEGMENT REPORTING :

As per Accounting Standard (AS) 17 on "Segment Reporting", segment information has been provided under the Notes to Consolidated Financial Statements.

2.46. The company has filed revised returns / made additional claims in respect of certain deductions and exemptions. These claims have been rejected by the Assessing Officer against which the company has preferred an appeal before the Commissioner of Income Tax (Appeals). Necessary adjustments in respect of Income Tax / MAT Credit Entitlements would be recognised in the books of account as and when the appeals are disposed off.

2.47. CSR EXPENDITURE :

	2016-17 ₹ Million	2015-16 ₹ Million
i) Gross amount required to be spent by the company during the year	—	—
ii) Amount spent during the year	3.950	—

Particulars	Incurred	Yet to be incurred	Total
a) Construction / acquisition of any asset	—	—	—
b) On other purpose other than (a) above	3.950	—	3.950

2.48. DETAILS OF SPECIFIED BANK NOTES (SBN) :

₹ Million

Particulars	Details of SBN	Other than SBN	Total
Closing Cash in hand as on 8th November, 2016	2.192	0.582	2.774
Transactions between 9th November, 2016 and 30th December, 2016			
Add : Permitted Receipts	20.010	20.800	40.810
Less : Permitted Payments	—	2.409	2.409
Less : Amount Deposited in Banks	22.202	17.210	39.412
Closing Cash in hand as on 30th December, 2016	—	1.763	1.763

2.49. EXCEPTIONAL ITEMS :

Profit on Sale of Investment - Wholly owned subsidiary
M/s. Integral Investments Limited #

5.337

—

Consideration received from M/s. Visteon Technical and Service Center Private Limited towards goodwill and transfer of technology in relation to the products manufactured for Renault Nissan.

—

82.500

5.337

82.500

On 15th June, 2016, the Company sold its 100% shareholding in its wholly owned subsidiary company M/s. Integral Investments Limited for a consideration of ₹27.837 Million resulting in a profit of ₹5.337 Million.

NOTES TO FINANCIAL STATEMENTS (Contd.,)

2.50. DISCLOSURE RELATING TO SUPPLIERS REGISTERED UNDER MICRO, SMALL AND MEDIUM ENTERPRISE DEVELOPMENT ACT, 2006 :

Particulars	As at 31-3-2017 ₹ Million	As at 31-3-2016 ₹ Million
The principal amount and the interest due thereon remaining unpaid to any supplier as at the end of each accounting year included in :		
Principal amount due to Micro and Small Enterprises	31.641	—
Interest due on above	—	—
Total	31.641	—
The amount of interest paid by the buyer in terms of Section 16 of the MSMED Act, 2006 along with the amounts of the payment made to the supplier beyond appointed day.	—	—
The amount of interest due and payable for the period of delay in making payment (which have been paid but beyond the appointment day during the year) but without adding the interest specified under the MSMED Act, 2006.	—	—
The amount of interest accrued and remaining unpaid at the end of each accounting year.	—	—
The amount of further interest remaining due and payable even in the succeeding years, until such date when the interest dues as above are actually paid for the purpose of disallowance as a deductible under Section 23 of the MSMED Act, 2006.	—	—

2.51. Deletion to Freehold Land represents Donation of a piece of Land having restricted use, to a public charitable institution for which the conveyance and registration formalities are pending.

2.52. The Board of Directors of the Company have recommended a dividend of ₹ 1/- per share, (100% on the face value of ₹ 1/-) aggregating to ₹ 94.797 Million on the equity shares of the company for the year ended 31st March, 2017, which is subject to the approval of the shareholders at the Annual General Meeting. The Ministry of Corporate Affairs through amendments to Companies (Accounting Standards) Amendment Rules, 2016, dated 30th March, 2016 has amended Accounting Standard (AS)-4 "Contingencies and Events occurring after Balance Sheet date". Consequently, the company has not accounted for proposed dividend as liability as at 31st March, 2017.

2.53. Previous year's figures are reclassified wherever necessary to conform to the current year's classification.

2.54. All figures are in Million unless otherwise stated.

2.55. RELATED PARTY DISCLOSURE AS PER ACCOUNTING STANDARD 18 :

(i) Names of related parties and description of relationship:

1. Enterprises where control exists :

Subsidiary Companies : PT Pricol Surya Indonesia, Pricol Asia Pte. Limited, Singapore, Pricol do Brasil Componentes Automotivos Ltda, Brazil, (Subsidiary of Pricol Espana S.L. Spain), Pricol Espana S.L. Spain, Integral Investments Limited, India - Disposed off in current year, Coimbatore Metal Works Limited, India - Disposed off during 2015-16.

2. Related parties where significant influence exists and with whom transactions have taken place during the year :

- a) **Partnership firms under common control :** Bhavani Global Enterprises, Ellargi & Co, Libra Industries.
- b) **Public Limited Companies :** Pricol Holdings Limited, PPL Enterprises Limited, Pricol Properties Limited, Pricol Technologies Limited, Pricol Travel Limited, Pricol Engineering Industries Limited, Pricol Corporate Services Limited, Printra Limited, Target Manpower Services Limited.
- c) **Key Management Personnel :** Mrs. Vanitha Mohan, Mr. Vikram Mohan
- d) **Relatives of Key Management Personnel :** Mr. Vijay Mohan

NOTES TO FINANCIAL STATEMENTS (Contd.,)

Related Party disclosure as per Accounting Standard 18 (Contd.,)

(ii) Related party transactions:

	2016-17 ₹ Million	2015-16 ₹ Million		2016-17 ₹ Million	2015-16 ₹ Million
Transactions during the year					
Purchase / Labour Charges					
PT Pricol Surya Indonesia	2.170	—	Bhavani Global Enterprises	5.248	—
Pricol Asia Pte. Limited	1,462.833	—	Pricol Holdings Limited	0.060	—
Ellargi & Co.	0.155	—	PPL Enterprises Limited	0.045	—
Libra Industries	185.982	—	Pricol Technologies Limited	5.190	—
PPL Enterprises Limited	63.443	—	Pricol Travel Limited	0.078	—
Pricol Technologies Limited	0.096	—	Pricol Engineering Industries Limited	13.435	—
Pricol Engineering Industries Limited	0.780	—	Pricol Corporate Services Limited	0.599	—
			Target Manpower Services Limited	0.016	—
Sales / Job Work Charges			Loans and advances given / (repaid)		
PT Pricol Surya Indonesia	70.237	—	Pricol Properties Limited	3.337	—
Pricol do Brasil Componentes Automotivos Ltda	0.001	—	Pricol Travel Limited	0.058	—
Libra Industries	1.789	—	Pricol Technologies Limited	(0.685)	—
PPL Enterprises Limited	0.663	—	Investments made / (disposed)		
Pricol Technologies Limited	0.003	—	PT Pricol Surya Indonesia	134.325	—
Pricol Engineering Industries Limited	0.339	—	Pricol Espana S.L. Spain	348.144	—
			Integral Investments Limited	(22.500)	—
Receiving of Services / Reimbursement of Expenses Paid			Guarantees provided / (released)		
PPL Enterprises Limited	1.225	—	Coimbatore Metal Works Limited	(154.500)	—
Pricol Technologies Limited	115.091	—	PT Pricol Surya Indonesia	(112.666)	—
Pricol Travel Limited	357.018	—	(iii) Amount outstanding as at the balance sheet date :		
Pricol Corporate Services Limited	220.374	—	Trade and Other Receivables		
Target Manpower Services Limited	25.609	—	PT Pricol Surya Indonesia	36.299	—
Mr. Vijay Mohan	0.500	—	Pricol do Brasil Componentes Automotivos Ltda	0.005	—
Mrs. Vanitha Mohan	16.770	—	Pricol Espana S.L. Spain	9.737	—
Mr. Vikram Mohan	29.648	—	Bhavani Global Enterprises	0.422	—
			Libra Industries	0.446	—
Rendering of Services / Reimbursement of Expenses Received			PPL Enterprises Limited	0.056	—
PT Pricol Surya Indonesia	2.322	—	Pricol Technologies Limited	0.054	—
Pricol Espana S.L. Spain	0.881	—			

NOTES TO FINANCIAL STATEMENTS (Contd.,)

Related Party disclosure as per Accounting Standard 18 (Contd.,)

	2016-17 ₹ Million	2015-16 ₹ Million		2016-17 ₹ Million	2015-16 ₹ Million
Pricol Engineering Industries Limited	2.927	—	Mrs. Vanitha Mohan	10.086	—
Ellargi & Co.	0.007	—	Mr. Vikram Mohan	13.448	—
Pricol Corporate Services Limited	0.051	—	Investments		
Pricol Properties Limited	69.849	—	Pricol Espana S.L. Spain	684.365	—
Trade and Other Payables			PT Pricol Surya Indonesia	452.152	—
Pricol Asia Pte. Limited	24.091	—	Pricol Asia Pte. Limited	15.038	—
Libra Industries	29.446	—	Guarantees		
PPL Enterprises Limited	6.673	—	Pricol do Brasil Componentes		
Pricol Technologies Limited	25.050	—	Automotivos Ltda.	420.000	—
Pricol Travel Limited	33.270	—	PT Pricol Surya Indonesia	210.000	—
Target Manpower Services Limited	3.435	—			

2.56. DISCLOSURE AS REQUIRED UNDER REGULATION 53(f) SEBI LODR

₹ Million

Name of the Company	Status	As on 31-3-2017			As on 31-3-2016				
		Outstanding Amount Loan / Advance	Maximum Loan / Advance outstanding during the year	Investment in shares of the Company	Direct investment in shares of subsidiaries of the Company	Outstanding Amount Loan / Advance	Maximum Loan / Advance outstanding during the year	Investment in shares of the Company	Direct investment in shares of subsidiaries of the Company
Pricol Espana S.L. Spain	Subsidiary	—	—	—	684.365	—	—	—	—
PT Pricol Surya Indonesia	Subsidiary	—	—	—	452.152	—	—	—	—
Pricol Asia Pte Limited, Singapore	Subsidiary	—	—	—	15.038	—	—	—	—
Integral Investments Limited # India	Subsidiary	—	—	—	22.500	—	—	—	—

Disposed off in current year

As per our report of even date attached
For Haribhakti & Co. LLP
Chartered Accountants
ICAI Firm Regn. No. 103523W/W100048
Kaushik Sidartha
Partner
Membership No. 217964
Coimbatore, 30th May 2017

Vijay Mohan
Chairman
(DIN : 00001843)

S. Shrinivasan
Chief Financial Officer
(ACMA No. : 17505)

For and on behalf of the Board

Vanitha Mohan
Vice Chairman
(DIN : 00002168)

Vikram Mohan
Managing Director
(DIN : 00089968)

T. G. Thamizhanban
Company Secretary
(FCS No. 7897)

INDEPENDENT AUDITORS' REPORT ON THE CONSOLIDATED FINANCIAL STATEMENTS

To the Members of Pricol Limited (Formerly, Pricol Pune Limited)

Report on the Consolidated Financial Statements

We have audited the accompanying consolidated financial statements of **Pricol Limited (Formerly Pricol Pune Limited)** (hereinafter referred to as "**the Holding Company**") and its subsidiaries (the Holding Company and its subsidiaries together referred to as "**the Group**"), comprising of the Consolidated Balance Sheet as at 31st March, 2017, the Consolidated Statement of Profit and Loss and the Consolidated Cash Flow Statement for the year then ended, and a summary of the significant accounting policies and other explanatory information (hereinafter referred to as "**the Consolidated Financial Statements**").

Management's Responsibility for the Consolidated Financial Statements

The Holding Company's Board of Directors is responsible for the preparation of these Consolidated Financial Statements in terms of the requirements of the Companies Act, 2013 (hereinafter referred to as "**the Act**") that give a true and fair view of the consolidated financial position, consolidated financial performance and consolidated cash flows of the Group in accordance with the accounting principles generally accepted in India, including the Accounting Standards specified under Section 133 of the Act, read with Rule 7 of the Companies (Accounts) Rules, 2014. The respective Board of Directors of the companies included in the Group are responsible for maintenance of adequate accounting records in accordance with the provisions of the Act for safeguarding the assets of the Group and for preventing and detecting frauds and other irregularities; the selection and application of appropriate accounting policies; making judgments and estimates that are reasonable and prudent; and design, implementation and maintenance of adequate internal financial controls, that were operating effectively for ensuring the accuracy and completeness of the accounting records, relevant to the preparation and presentation of the financial statements that give a true and fair view and are free from material misstatement, whether due to fraud or error, which have been used for the purpose of preparation of the Consolidated Financial Statements by the Directors of the Holding Company, as aforesaid.

Auditors' Responsibility

Our responsibility is to express an opinion on these Consolidated Financial Statements based on our audit.

While conducting the audit, we have taken into account the provisions of the Act, the accounting and auditing standards and matters which are required to be included in the audit report under the provisions of the Act and the Rules made thereunder.

We conducted our audit in accordance with the Standards on Auditing specified under Section 143(10) of the Act. Those Standards require that we comply with ethical requirements and plan and perform the audit to obtain reasonable assurance about whether the Consolidated Financial Statements are free from material misstatement.

An audit involves performing procedures to obtain audit evidence about the amounts and disclosures in the Consolidated Financial Statements. The procedures selected depend on the auditor's judgment, including the assessment of the risks of material misstatement of the consolidated financial statements, whether due to fraud or error. In making those risk assessments, the auditor considers internal financial control relevant to the Holding Company's preparation of the Consolidated Financial Statements that give a true and fair view in order to design audit procedures that are appropriate in the circumstances. An audit also includes evaluating the appropriateness of accounting policies used and the reasonableness of the accounting estimates made by the Holding Company's Board of Directors, as well as evaluating the overall presentation of the Consolidated Financial Statements.

We believe that the audit evidence obtained by us and the audit evidence obtained by the other auditors in terms of their report referred to in sub-paragraph (a) of the Other Matters paragraph below, is sufficient and appropriate to provide a basis for our audit opinion on the consolidated financial statements.

Opinion

In our opinion and to the best of our information and according to the explanations given to us and based on the consideration of reports of other auditors on separate financial statements and on the other financial information of the subsidiaries, the aforesaid Consolidated Financial Statements give the information required by the Act in the manner so required and give a true and fair view in conformity with the accounting principles generally accepted in India, of the consolidated state of affairs of the Group, as at 31st March, 2017, their consolidated profit and their consolidated cash flows for the year ended on that date.

INDEPENDENT AUDITOR'S REPORT ON THE CONSOLIDATED FINANCIAL STATEMENTS (Contd.,)

Emphasis of Matter

We draw attention to the following matters in the notes to the Consolidated Financial Statements:

- (a) Note No. 2.32 with regard to the Scheme of Amalgamation sanctioned by the Honourable High Court of Judicature at Madras; and
- (b) Note No. 2.34 with regard to the modified opinion given by the component auditor of Pricol do Brasil Componentes Automotivos LtdA. on the recognition of deferred tax asset from tax losses and other temporary differences and the accounting treatment in the consolidated financial statements.

Our opinion is not modified in respect of these matters.

Other Matters

- (a) We did not audit the financial statements of 3 subsidiaries, whose financial statements reflects total assets of ₹ 1,787.954 Million and net assets of ₹ 56.061 Million as at 31st March, 2017, total revenues of ₹ 3,721.767 Million and net cash flows amounting to ₹ 129.129 Million for the year ended on that date, as considered in the Consolidated Financial Statements. These financial statements have been audited by other auditors whose reports have been furnished to us by the Management and our opinion on the Consolidated Financial Statements, in so far as it relates to the amounts and disclosures included in respect of these subsidiaries, and our report in terms of sub-section (3) of Section 143 of the Act, in so far as it relates to the aforesaid subsidiaries, is based solely on the reports of the other auditors.

The subsidiaries are located outside India whose financial statements have been prepared in accordance with accounting principles generally accepted in their respective countries and which have been audited by other auditors under generally accepted auditing standards applicable in their respective countries. The Company's management has converted the financial statements of such subsidiaries located outside India from accounting principles generally accepted in their respective countries to accounting principles generally accepted in India. We have audited these conversion adjustments made by the Company's management. Our opinion in so far as it relates to the balances and affairs of such subsidiaries located outside India is based on the report of other auditors and the

conversion adjustments prepared by the management of the Company and audited by us.

- (b) We did not audit the financial statements of 2 subsidiaries, whose financial statements reflect total assets of ₹ 644.982 Million and net assets of ₹ 635.590 Million as at 31st March, 2017, total revenues of ₹ 1.592 Million and net cash flows amounting to ₹ 28.379 Million for the year ended on that date, as considered in the Consolidated Financial Statements. These financial statements are unaudited and have been furnished to us by the Management and our opinion on the Consolidated Financial Statements, in so far as it relates to the amounts and disclosures included in respect of these subsidiaries, and our report in terms of sub-section (3) of Section 143 of the Act, in so far as it relates to the aforesaid subsidiaries, is based solely on such unaudited financial statements. In our opinion and according to the information and explanations given to us by the Management, these financial statements are not material to the Group.

Our opinion on the Consolidated Financial Statements and our report on the Other Legal and Regulatory Requirements below, is not modified in respect of the above matters with respect to our reliance on the work done and the reports of the other auditors and the financial statements certified by the management.

Report on Other Legal and Regulatory Requirements

As required by Section 143(3) of the Act, we report, to the extent applicable, that:

- a. We have sought and obtained all the information and explanations which to the best of our knowledge and belief were necessary for the purposes of our audit of the aforesaid Consolidated Financial Statements;
- b. In our opinion, proper books of account as required by law relating to preparation of the aforesaid Consolidated Financial Statements have been kept by the Company so far as it appears from our examination of those books and the reports of the other auditors;
- c. The Consolidated Balance Sheet, the Consolidated Statement of Profit and Loss and the Consolidated Cash Flow Statement dealt with by this Report are in agreement with the relevant books of account maintained for the purpose of preparation of the Consolidated Financial Statements;
- d. In our opinion, the aforesaid Consolidated Financial Statements comply with the Accounting Standards

INDEPENDENT AUDITOR'S REPORT ON THE CONSOLIDATED FINANCIAL STATEMENTS (Contd.)

specified under Section 133 of the Act read with Rule 7 of the Companies (Accounts) Rules, 2014;

- e. On the basis of written representations received from the directors of the Holding Company as on 31st March, 2017 taken on record by the Board of Directors of the Holding Company, none of the directors of the Holding Company is disqualified as on 31st March, 2017 from being appointed as a director in terms of Section 164 (2) of the Act. The Group did not have any subsidiary, joint ventures and associates incorporated in India as at the end of the reporting period;
- f. With respect to the adequacy of the internal financial controls over financial reporting of the Group, and the operating effectiveness of such controls, we give our separate Report in the "Annexure".
- g. With respect to the other matters to be included in the Auditor's Report in accordance with Rule 11 of the Companies (Audit and Auditors) Rules, 2014, in our opinion and to the best of our information and according to the explanations given to us:
- (i) The Consolidated Financial Statements disclose the impact of pending litigations on the consolidated financial position of the Group, Refer Note 2.36 to the Consolidated Financial Statements;
- (ii) Provision has been made in the Consolidated Financial Statements, as required under the

applicable law or accounting standards, for material foreseeable losses, if any, on long-term contracts including derivative contracts - Refer Note 2.40 to the Consolidated Financial Statements in respect of such items as it relates to the Group;

- (iii) There were no amounts which were required to be transferred to the Investor Education and Protection Fund by the Holding Company and its subsidiary companies incorporated in India ;
- (iv) The Holding Company and its subsidiary companies incorporated in India have provided requisite disclosures in its financial statements as to holdings as well as dealings in Specified Bank Notes during the period from 8th November, 2016 to 30th December, 2016. Based on audit procedures performed by us, we report that the disclosures are in accordance with the books of account maintained by the Holding Company and its subsidiary companies incorporated in India - Refer Note No. 2.43 to the consolidated financial statements.

For Haribhakti & Co. LLP
Chartered Accountants

ICAI Firm Registration No.103523W/W100048

Kaushik Sidartha

Partner

Membership No.: 217964

Coimbatore
30th May, 2017

ANNEXURE TO THE INDEPENDENT AUDITOR'S REPORT

[Referred to under 'Report on Other Legal and Regulatory Requirements' in the Independent Auditor's Report of even date to the members of **Pricol Limited (Formerly Pricol Pune Limited)** ('Holding Company') on the consolidated financial statements for the year ended 31st March, 2017].

Report on the Internal Financial Controls under Clause (i) of Sub-section 3 of Section 143 of the Companies Act, 2013 ("the Act")

In conjunction with our audit of the consolidated financial statements of the Company as of and for the year ended 31st March, 2017, We have audited the internal financial controls over financial reporting of the Holding Company and its subsidiary company incorporated in India, as of that date.

Management's Responsibility for Internal Financial Controls

The Board of Directors of the Group, is responsible for establishing and maintaining internal financial controls based on the internal control over financial reporting criteria established by the Company considering the essential components of internal control stated in the Guidance Note on Audit of Internal Financial Controls Over Financial Reporting issued by the Institute of Chartered Accountants of India (ICAI). These responsibilities include the design, implementation and maintenance of adequate internal financial controls that were operating effectively for ensuring the orderly and efficient conduct of its business, including adherence to the respective company's policies, the safeguarding of its assets, the prevention and detection of frauds and errors, the accuracy and completeness of the accounting records, and the timely preparation of reliable financial information, as required under the Companies Act, 2013.

INDEPENDENT AUDITOR'S REPORT ON THE CONSOLIDATED FINANCIAL STATEMENTS (Contd.,)

Auditor's Responsibility

Our responsibility is to express an opinion on the Company's internal financial controls over financial reporting based on our audit. We conducted our audit in accordance with the Guidance Note on Audit of Internal Financial Controls Over Financial Reporting (the "Guidance Note") and the Standards on Auditing specified under section 143(10) of the Act, to the extent applicable to an audit of internal financial controls, both issued by the ICAI. Those Standards and the Guidance Note require that we comply with ethical requirements and plan and perform the audit to obtain reasonable assurance about whether adequate internal financial controls over financial reporting was established and maintained and if such controls operated effectively in all material respects.

Our audit involves performing procedures to obtain audit evidence about the adequacy of the internal financial controls system over financial reporting and their operating effectiveness. Our audit of internal financial controls over financial reporting included obtaining an understanding of internal financial controls over financial reporting, assessing the risk that a material weakness exists, and testing and evaluating the design and operating effectiveness of internal control based on the assessed risk. The procedures selected depend on the auditor's judgement, including the assessment of the risks of material misstatement of the financial statements, whether due to fraud or error.

We believe that the audit evidence we have obtained is sufficient and appropriate to provide a basis for our audit opinion on the Company's internal financial controls system over financial reporting.

Meaning of Internal Financial Controls Over Financial Reporting

A company's internal financial control over financial reporting is a process designed to provide reasonable assurance regarding the reliability of financial reporting and the preparation of financial statements for external purposes in accordance with generally accepted accounting principles. A company's internal financial control over financial reporting includes those policies and procedures that (1) pertain to the maintenance of records that, in reasonable detail, accurately and fairly reflect the

transactions and dispositions of the assets of the company; (2) provide reasonable assurance that transactions are recorded as necessary to permit preparation of financial statements in accordance with generally accepted accounting principles, and that receipts and expenditures of the company are being made only in accordance with authorisations of management and directors of the company; and (3) provide reasonable assurance regarding prevention or timely detection of unauthorised acquisition, use, or disposition of the company's assets that could have a material effect on the financial statements.

Inherent Limitations of Internal Financial Controls Over Financial Reporting

Because of the inherent limitations of internal financial controls over financial reporting, including the possibility of collusion or improper management override of controls, material misstatements due to error or fraud may occur and not be detected. Also, projections of any evaluation of the internal financial controls over financial reporting to future periods are subject to the risk that the internal financial control over financial reporting may become inadequate because of changes in conditions, or that the degree of compliance with the policies or procedures may deteriorate.

Opinion

In our opinion, the Holding Company and its subsidiary companies incorporated in India have, in all material respects, an adequate internal financial controls system over financial reporting and such internal financial controls over financial reporting were operating effectively as at 31st March, 2017, based on the internal control over financial reporting criteria established by the Company considering the essential components of internal control stated in the Guidance Note on Audit of Internal Financial Controls Over Financial Reporting issued by the ICAI.

For Haribhakti & Co. LLP
Chartered Accountants
ICAI Firm Registration No.103523W/W100048
Kaushik Sidartha
Partner
Coimbatore
30th May, 2017
Membership No.: 217964

★★★★★

CONSOLIDATED BALANCE SHEET AS AT 31st MARCH 2017

	Note No.	31-3-2017 ₹ Million
I. EQUITY AND LIABILITIES		
(1) Shareholders' Funds		
(a) Share Capital	2.1	94.797
(b) Reserves and Surplus	2.2	7,131.794
(2) Non Current Liabilities		
(a) Long Term Borrowings	2.3	243.105
(b) Deferred Tax Liabilities (Net)	2.4	422.398
(c) Long Term Provisions	2.5	201.365
(d) Other Non Current Liabilities	2.6	98.651
(3) Current Liabilities		
(a) Short Term Borrowings	2.7	941.966
(b) Trade Payables	2.8	2,410.180
(c) Other Current Liabilities	2.9	1,309.767
(d) Short Term Provisions	2.10	61.185
Total		12,915.208
II. ASSETS		
(1) Non Current Assets		
(a) Fixed Assets	2.11	
(i) Property, Plant and Equipment		4,380.388
(ii) Intangible Assets		3,001.870
(iii) Capital Work-in-progress		266.528
(b) Long Term Loans and Advances	2.12	222.191
(c) Other Non-Current Assets	2.13	481.491
(2) Current Assets		
(a) Current Investments	2.14	2.100
(b) Inventories	2.15	1,729.437
(c) Trade Receivables	2.16	2,111.825
(d) Cash and Cash Equivalents	2.17	279.033
(e) Short Term Loans and Advances	2.18	403.416
(f) Other Current Assets	2.19	36.929
Total		12,915.208

Significant Accounting Policies & Notes form an integral part of the Consolidated Financial Statements

As per our report of even date attached
For Haribhakti & Co. LLP
Chartered Accountants
ICAI Firm Regn. No. 103523W/W100048
Kaushik Sidartha
Partner
Membership No. 217964
Coimbatore, 30th May 2017

Vijay Mohan
Chairman
(DIN : 00001843)

S. Shrinivasan
Chief Financial Officer
(ACMA No. : 17505)

For and on behalf of the Board

Vanitha Mohan
Vice Chairman
(DIN : 00002168)

Vikram Mohan
Managing Director
(DIN : 00089968)

T. G. Thamizhanban
Company Secretary
(FCS No. 7897)

CONSOLIDATED STATEMENT OF PROFIT & LOSS FOR THE YEAR ENDED 31st MARCH 2017

	Note No.	2016-17 ₹ Million
INCOME		
Revenue from Operations (Gross)		15,518.868
Less : Excise Duty		1,288.467
Revenue from Operations (Net)	2.20	14,230.401
Other Operating Revenue	2.21	501.968
Other Income	2.22	83.374
Total Revenue		14,815.743
EXPENSES		
Cost of Materials Consumed	2.23	9,096.811
Purchases of Stock-in-Trade		542.377
Changes in inventories of Work-in-progress, Finished Goods and Stock-in-Trade	2.24	(245.903)
Employee Benefits Expense	2.25	2,416.688
Finance Costs	2.26	176.548
Depreciation and Amortisation Expense	2.27	734.824
Other Expenses	2.28	1,847.400
Total Expenses		14,568.745
Profit from operations before Exceptional Items and Tax		246.998
Add : Exceptional Items	2.29	10.500
Profit Before Tax		257.498
Less : Tax Expense		
Current Tax		148.831
Deferred Tax		172.024
MAT Credit		(137.000)
For earlier years		(0.210)
Profit for the year		73.853
Earnings per Equity Share (Face Value of ₹ 1/-) in Rupees	2.30	
Basic & Diluted		0.78

Significant Accounting Policies & Notes form an integral part of the Consolidated Financial Statements

As per our report of even date attached
For Haribhakti & Co. LLP
Chartered Accountants
ICAI Firm Regn. No. 103523W/W100048
Kaushik Sidartha
Partner
Membership No. 217964
Coimbatore, 30th May 2017

Vijay Mohan
Chairman
(DIN : 00001843)

S. Shrinivasan
Chief Financial Officer
(ACMA No. : 17505)

For and on behalf of the Board

Vanitha Mohan
Vice Chairman
(DIN : 00002168)

Vikram Mohan
Managing Director
(DIN : 00089968)

T. G. Thamizhanban
Company Secretary
(FCS No. 7897)

CONSOLIDATED CASHFLOW STATEMENT FOR THE YEAR ENDED 31st MARCH 2017

	2016-17 ₹ Million
A. CASH FLOW FROM OPERATING ACTIVITIES :	
Net Profit Before Tax	257.498
Adjustments for :	
Depreciation & Amortisation Expense	734.824
Bad debts written off	1.679
Provision for doubtful debts and advances	11.574
Provision for doubtful debts and advances written back	(2.243)
Provision for Diminution in Value of Current Investments written back	(0.370)
(Profit) / Loss on sale of assets (Net)	(3.772)
Assets Discarded / Written off	13.564
Profit on Sale of Investment - Exceptional Item	(10.500)
Effect of Change in Foreign Currency Translation Reserve	(104.431)
Interest received	(10.553)
Exchange Fluctuation (Gain) / Loss on Re-statement	(1.834)
Income from Current Investments	(0.482)
Finance Costs	176.548
	804.004
Operating Profit before working capital changes	1,061.502
Adjustments for :-	
(Increase) / Decrease in Trade and other receivables	319.381
Adjustment on Amalgamation (Net)	(28.152)
(Increase) / Decrease in Inventories	(255.202)
Increase / (Decrease) in Trade and other payables	(335.939)
	(299.912)
Cash generated from Operations	761.590
Direct taxes	(150.032)
Net cash from operating activities	611.558
B. CASH FLOW FROM INVESTING ACTIVITIES :	
Purchase of Fixed Assets	(895.297)
Sale of Fixed Assets	21.823
Purchase of Investments	(1,338.900)
Sale of Investments	1,370.235
Interest received	10.553
Net Cash (used in) / from investing activities	(831.586)
C. CASH FLOW FROM FINANCING ACTIVITIES :	
Increase / (Decrease) in Working Capital Borrowings	557.393
Increase / (Decrease) in Long Term Borrowings	(41.140)
Dividend & Tax on Dividend Paid	(112.118)
Finance Costs paid	(174.521)
Net Cash (used in) / from financing activities	229.614
D. NET INCREASE / (DECREASE) IN CASH AND CASH EQUIVALENTS (A+B+C)	9.586
Cash and Bank Balances as at 1.4.2016 (Opening Balance)	12.773
Add : Pursuant to Scheme of Amalgamation	256.674
Less : Bank Balances not considered as Cash and Cash equivalents as per Accounting Standard AS 3	220.543
Cash and cash equivalents as at 31.3.2017 (Closing Balance) (Refer to Note No. 2.17)	58.490

Significant Accounting Policies & Notes form an integral part of the Consolidated Financial Statements

As per our report of even date attached

For Haribhakti & Co. LLP

Chartered Accountants

ICAI Firm Regn. No. 103523W/W100048

Kaushik Sidartha

Partner

Membership No. 217964

Coimbatore, 30th May 2017

Vijay Mohan

Chairman

(DIN : 00001843)

S. Shrinivasan

Chief Financial Officer

(ACMA No. : 17505)

For and on behalf of the Board

Vanitha Mohan

Vice Chairman

(DIN : 00002168)

Vikram Mohan

Managing Director

(DIN : 00089968)

T. G. Thamizhanban

Company Secretary

(FCS No. 7897)

NOTES TO CONSOLIDATED FINANCIAL STATEMENTS FOR THE YEAR ENDED 31st MARCH 2017

1. SIGNIFICANT ACCOUNTING POLICIES TO THE CONSOLIDATED BALANCE SHEET AND STATEMENT OF PROFIT AND LOSS

A. Basis of Preparation of Consolidated Financial Statements :

These consolidated financial statements have been prepared to comply with the Generally Accepted Accounting Principles in India (Indian GAAP), including the Accounting Standards notified under the relevant provisions of the Companies Act, 2013.

B. Principles of Consolidation :

The consolidated financial statements relate to Pricol Limited (Formerly Pricol Pune Limited) ("the Company") and its subsidiary companies. The Consolidated financial statements have been prepared on the following basis:

- i) The financial statements of the Company and its subsidiary companies are combined on a line-by-line basis by adding together the book values of like items of assets, liabilities, income and expenses, after fully eliminating intra-group balances and intra-group transactions resulting in unrealised profit or losses in accordance with Accounting Standard (AS) 21 – "Consolidated Financial Statements".
- ii) In case of foreign subsidiaries, being non-integral foreign operations, revenue items are consolidated at the average rate prevailing during the year. All assets and liabilities are converted at rates prevailing at the end of the year. Any exchange difference arising on consolidation is recognised in the foreign exchange translation reserve as per Accounting Standard (AS) 11 – "Effect of Changes in Foreign Exchange Rates".
- iii) The difference between the cost of investment in the subsidiaries over the net assets at the time of acquisition of shares in the subsidiaries is recognised in the financial statements as Goodwill or Capital Reserve as the case may be.
- iv) As far as possible, the consolidated financial statements are prepared using uniform accounting policies for like transactions and other events in similar circumstances and are presented in the same manner as the Company's separate financial statements.

C. Investments other than in subsidiaries and associates have been accounted as per Accounting Standard (AS) 13 – "Accounting for Investments".

D. Other Significant Accounting Policies :

I. Use of estimates :

The preparation of financial statements requires management to make estimates and assumptions that

affect the reported amount of assets, liabilities, disclosures relating to contingent liabilities and assets as at the balance sheet date and the reported amounts of income and expenses during the year. Difference between the actual amounts and the estimates are recognised in the year in which the events become known / are materialised. Although these estimates are based on the management's best knowledge of current events and actions, uncertainty about these assumptions and estimates could result in the outcomes requiring a material adjustment to the carrying amounts of assets or liabilities in future periods.

II. Property, Plant & Equipment and Depreciation :

- a) Property, Plant and Equipment (PPE), being fixed assets are tangible items that are held for use in the production or supply of goods or services, for rental to others, or for administrative purposes. They are measured at cost less accumulated depreciation and any accumulated impairment. Cost comprises of the purchase price including import duties and non-refundable purchase taxes after deducting trade discounts and rebates and any costs attributable to bringing the asset to the location and condition necessary for it to be capable of operating in the manner intended by the Management.
- b) Items such as spare parts, stand-by equipment and servicing equipment are capitalised if they meet the definition of property, plant and equipment.
- c) Depreciation on Property, Plant and Equipment (PPE) are provided as per the estimated useful lives.
- d) Where the cost of a part of the PPE is significant to the total cost of the PPE and if that part of the PPE has a different useful life than the main PPE, the useful life of that part is determined separately for depreciation.
- e) The depreciation method applied to an asset is reviewed at each financial year-end and if there has been a significant change in the expected pattern of consumption of future economic benefits embodied in the asset, depreciation is charged prospectively to reflect the changed pattern.
- f) The carrying amount of an item of PPE is de-recognised on disposal or when no future economic benefits are expected from its use or disposal. Gains or losses arising from de-recognition of Property, Plant and equipment are measured as the difference between the net disposal proceeds and the carrying amount of the

NOTES TO CONSOLIDATED FINANCIAL STATEMENTS (Contd.,)

asset and are recognized in the statement of profit and loss when the asset is derecognised.

III. Intangible assets and amortisation :

- a) Intangible assets are recognised only if it is probable that future economic benefits that are attributable to the asset will flow to the enterprise and the cost of the asset can be measured reliably.
- b) The Group amortises intangible assets based on the estimated useful lives of the intangible assets.

IV. Impairment of assets :

The Group periodically assesses whether there is any indication that an asset or a group of assets comprising a cash generating unit may be impaired. If any such indication exists, the Group estimates the recoverable amount of the asset. If such recoverable amount of the asset or the recoverable amount of the cash generating unit to which the asset belongs is less than its carrying amount, the carrying amount is reduced to its recoverable amount. The reduction is treated as an impairment loss and is recognised in the statement of profit and loss. If at the balance sheet date there is an indication that if a previously assessed impairment loss no longer exists, the recoverable amount is reassessed and the asset is reflected at the recoverable amount subject to a maximum of depreciable historical cost. An impairment loss is reversed only to the extent that the amount of asset does not exceed the net book value that would have been determined if no impairment loss had been recognised.

V. Valuation of Inventories :

- a) Inventories are valued at lower of cost and estimated net realisable value.
- b) The basis of determining cost for various categories of inventories is as follows:-
 - i) Raw Materials, Packing Materials and Stores & spares : Weighted Average Basis.
 - ii) Finished Goods and Work-in-progress : Cost of Direct Material, Labour and other Manufacturing overheads
- c) Stores & Spares which do not meet the definition of Property, Plant and Equipment are accounted as inventories.
- d) Net realisable value is the estimated selling price in the ordinary course of business, less estimated

cost of completion and estimated costs necessary to make the sale.

VI. Revenue Recognition :

- a) The Group generally follows the mercantile system of accounting and recognises Income and Expenditure on an accrual basis except those with significant uncertainties.
- b) Sale of goods is recognised when the risks and rewards of ownership are passed on to the customers as per the terms of contract.
- c) Dividend Income is recognised when the right to receive the dividend is unconditional at the Balance Sheet date.
- d) Interest is recognised on a time proportion basis taking into account the amount outstanding and the rate applicable.

VII. Foreign Currency Transactions :

- a) Foreign Currency Transactions are recorded at exchange rates prevailing on the date of such transaction.
- b) Exchange differences arising on settlement of transactions of monetary items are recognised as income / expense in the Statement of Profit & Loss in the period in which it arises.
- c) Foreign monetary currency assets and liabilities at the year end are realigned at the exchange rate prevailing at the year end and difference on realignment is recognised in the Statement of Profit & Loss.

VIII. Employee Benefits:

- a) Short-term employee benefits are recognised as an expense at the undiscounted amount in the Statement of Profit and Loss of the year in which the related service is rendered.
- b) Post employment and other long term benefits, which are defined benefit plans, are recognised as an expense in the Statement of Profit and Loss for the year in which the employee has rendered service. The expense is recognised based on the present value of the obligation determined as per Projected Unit Credit Method.

IX. Borrowing Costs :

- a) Borrowing Costs attributable to the acquisition or construction of qualifying assets are capitalised as part of such assets. All other borrowing costs are charged to revenue.

NOTES TO CONSOLIDATED FINANCIAL STATEMENTS (Contd.,)

- b) A qualifying asset is an asset that necessarily requires substantial period of time to get ready for its intended use or sale.

X. Taxes on Income :

- a) Current tax on income for the period is determined on the basis of taxable income and tax credits computed in accordance with the provisions of the prevailing tax laws in the respective countries.
- b) Deferred tax is recognised using the tax rates and laws enacted or substantively enacted as on the Balance Sheet date.
- c) Deferred tax assets are recognised only to the extent there is reasonable certainty that the assets can be realised in the future.
- d) Deferred tax assets and Deferred tax liabilities are offset if a legally enforceable right exist to set off current tax assets against current tax liabilities and deferred tax assets/deferred tax liabilities relate to same taxable entity and same taxation authority.

XI. Leases :

- a) Leases are classified as finance or operating leases depending upon the terms of the lease agreements. Assets held under finance leases are recognised as assets of the Company on the date of acquisition and depreciated over their estimated useful lives. Finance costs are treated as period cost using effective interest rate method and are expensed accordingly.
- b) Lease arrangements, where the risks and rewards incidental to the ownership of an asset substantially vest with the lessor, are recognised as an operating lease.
- c) The Assets given under operating leases are shown in Balance Sheet under Fixed Assets and depreciated on a basis consistent with the depreciation policy of the company. The lease income is recognised in the Statement of Profit and Loss on a straight line basis over the lease period.

XII. Earnings per Share :

- a) Basic earnings per share are calculated by dividing the net profit or loss for the period attributable to equity shareholders by the weighted average number of equity shares outstanding during the period. The weighted average number of equity shares outstanding during the period are adjusted for events of bonus

issue, bonus element in a rights issue to existing shareholders, share split and consolidation of shares, if any.

- b) For the purpose of calculating diluted earnings per share, the profit or loss for the period attributable to equity shareholders and the weighted average number of shares outstanding during the period are adjusted for the effects of all dilutive potential equity shares.

XIII. Provisions and Contingencies :

- a) A provision is recognised when an enterprise has a present obligation as a result of past event and it is probable that an outflow of resources would be required to settle the obligation, in respect of which a reliable estimate can be made. Provisions are not discounted to its present value and are determined based on best estimate required to settle the obligation at the balance sheet date. These are reviewed at each balance sheet date and adjusted to reflect the current best estimates.
- b) A Contingent liability is a possible obligation that arises from past events whose existence will be confirmed by the occurrence or non-occurrence of one or more uncertain future events beyond the control of the company or a present obligation that is not recognized because it is not probable that an outflow of resources will be required to settle the obligation. A contingent liability also arises in extremely rare cases where there is a liability that cannot be recognized because it cannot be measured reliably. The company does not recognize a contingent liability but discloses its existence in the financial statements.
- c) Contingent Assets are neither accounted for nor disclosed

XIV. Cash and Cash equivalents :

Cash flow is reported using the indirect method, whereby net profit / loss before tax is adjusted for the effects of transaction of a non cash nature and any deferrals or accruals of past or future cash receipts or payments.

The cash flow comprises regular revenue generating, investing and financing activities of the company. Cash and cash equivalents in the balance sheet comprise of cash at bank and in hand and short term, highly liquid investments which are subject to an insignificant risk of changes in value.

NOTES TO CONSOLIDATED FINANCIAL STATEMENTS (Contd.,)

31-3-2017
₹ Million

2.1. SHARE CAPITAL

Authorised

582,000,000 Equity Shares of ₹ 1/- each * 582.000

Issued, Subscribed and Paid-up

94,796,721 Equity Shares of ₹ 1/- each 94.797

* Pursuant to the Scheme of Amalgamation, the Authorised Share Capital of the Company stands increased to ₹ 582 Million from ₹ 100 Million. (Refer to Note No. 2.32)

Reconciliation of the Shares Outstanding at the beginning and at the end of the reporting period :

Equity Shares

	31-3-2017	
	No. of Shares Million	₹ Million
At the beginning of the period	100.000	100.000
Add : Shares allotted pursuant to Scheme of Amalgamation (Refer to Note No.2.32)	94.797	94.797
Less : Shares cancelled pursuant to Scheme of Amalgamation (Refer to Note No.2.32)	100.000	100.000
At the closing of the period	94.797	94.797

Terms / rights attached to equity shares :

The company has only one class of equity shares having a par value of ₹ 1/- per share. Each holder of equity shares is entitled to one vote per share. The company declares and pays dividend in Indian Rupees. The dividend proposed by the Board of Directors, if any, is subject to the approval of the shareholders in the ensuing Annual General Meeting. In the event of liquidation of the Company, the holders of the equity shares will be entitled to receive remaining assets of the company, after distribution of all preferential amount. The distribution will be in proportion to the number of equity shares held by the shareholders.

Details of Shareholders holding more than 5% shares in the company :

	31-3-2017	
	No. of Shares	% held
Equity Shares of ₹ 1/- each fully paid		
- Vijay Mohan	9,801,178	10.34%
- Pricol Holdings Limited	8,556,926	9.03%
- Viren Mohan	6,658,409	7.02%

Details of Shares held by Holding Company :

There are no Shares held by Holding Company / Subsidiaries of ultimate Holding Company as on 31st March 2017.

Details of Shares issued for consideration other than in cash :

94,796,721 shares of ₹ 1/- each were allotted for consideration other than cash during the current financial year in terms of the Scheme of Amalgamation with Erstwhile Pricol Limited which was sanctioned by the Hon'ble High Court of Judicature at Madras on 6th October 2016.

During the year 2011-12, 4,950,000 Equity Shares of ₹ 10/- each were allotted as fully paid-up pursuant to contract without payments being received in cash. During the year 2015-16, Erstwhile Pricol Limited acquired 5,000,000 Equity Shares of ₹ 10/- each from Johnson Control Enterprise Limited, UK. These shares were subsequently cancelled pursuant to Scheme of Amalgamation.

There were no shares allotted by way of Bonus Shares and there have been no shares bought back in the immediately preceding five years.

NOTES TO CONSOLIDATED FINANCIAL STATEMENTS (Contd.,)

31-3-2017
₹ Million

2.2. RESERVES & SURPLUS

Securities Premium Reserve

Opening Balance	684.000	
Add : Pursuant to Amalgamation (Refer to Note No. 2.32)	7,412.156	8,096.156

Capital Reserve

Opening Balance	—	
Add : Pursuant to Amalgamation	222.124	222.124

Statutory Reserve

Opening Balance	—	
Add : Pursuant to Amalgamation	10.003	
Less : Adjustment on disposal of interest in subsidiary	10.003	—

General Reserve

Opening Balance	—	
Add : Pursuant to Amalgamation	4.283	4.283

Surplus / (Deficit) in the Consolidated Statement of Profit & Loss

Opening Balance	(211.070)	
Add : Pursuant to Amalgamation (Refer to Note No. 2.32)	(962.412)	
Add : Profit for the year	73.853	(1,099.629)

Foreign Exchange Translation Reserve

Opening Balance	—	
Add : Pursuant to Amalgamation	(61.834)	
Add : Addition during the year	(29.306)	(91.140)
		<u>7,131.794</u>

2.3. LONG TERM BORROWINGS

	Non-Current Portion	Current Maturities
	31-3-2017	31-3-2017
	₹ Million	₹ Million
Secured Loans :		
a. Rupee Term Loan from Banks	133.333	183.333
b. Foreign Currency Term Loan from Banks	109.772	272.554
	<u>243.105</u>	<u>455.887</u>

Term loan from Indian bank is secured by way of hypothecation of machineries and other fixed assets of the Company. The rate of interest is 14.20% and the loan was repayable in four quarterly instalments after an initial holiday period of 2 years from the date of first availment. Interest to be serviced as and when charged. The above loan has been preclosed during the year 2016-17. Hence there is no outstanding as on 31st March 2017.

Term Loan of ₹ 300 Million for Medium Term Working Capital from Bank of Bahrain and Kuwait B.S.C. is repayable in 12 quarterly instalments of ₹ 25 Million each. Interest is payable on monthly basis at the rate of Bank Base Rate plus 0.10%. The loan is secured by pari-passu first charge on the specific land and building of Plant III situated at Billichi Village, Coimbatore District. Present Outstanding as on 31st March, 2017 is ₹ 50 Million.

NOTES TO CONSOLIDATED FINANCIAL STATEMENTS (Contd.,)

LONG TERM BORROWINGS (Contd.,)

Term Loan of ₹ 200 Million from HDFC Bank is repayable in 12 quarterly instalments of ₹ 16.667 Million each. Interest is payable on monthly basis at the rate of Bank Base Rate plus 0.50%. The loan is secured by pari-passu first charge by hypothecation of specific plant and machinery and pari-passu first charge by way of mortgage of immovable property situated at IMT Manesar, Gurugram. Present Outstanding as on 31st March, 2017 is ₹ 83.333 Million.

Term Loan of ₹ 200 Million from Federal Bank is repayable in 12 quarterly instalments of ₹ 16.667 Million each. Interest is payable on monthly basis at the rate of Bank Base Rate plus 0.10%. The loan is secured by Equitable mortgage of immovable property on pari-passu first charge basis and hypothecation of specific Plant & Machinery on pari-passu first charge basis with HDFC Bank. Present Outstanding as on 31st March, 2017 is ₹ 183.333 Million.

Term Loan of PT Pricol Surya Indonesia is secured by way of its land and factory building, inventories and Corporate Guarantee from Holding Company.

Term Loan of Pricol do Brasil Componentes Automotivos Ltda, Brazil is Guaranteed by Corporate Guarantee from Holding Company. The loan is repayable in May, 2018.

2.4. DEFERRED TAX LIABILITIES - (NET)	31-3-2017
	₹ Million
Deferred Tax Liability	
Fixed Assets	494.636
	494.636
Deferred Tax Asset	A
Expenditure disallowed for tax purposes but allowable in subsequent years	61.000
Unabsorbed Depreciation / Brought forward Business Loss	11.238
	B
	72.238
Deferred Tax Liability (Net)	A - B
	422.398
2.5. LONG TERM PROVISIONS	
For Employee Benefits :	
- Gratuity	46.752
For Central Excise Demands (Refer to Note No. 2.40)	69.158
For Potential Statutory Liabilities (Refer to Note No. 2.40)	54.836
For Labour related Claims (Refer to Note No. 2.40)	30.619
	201.365
2.6. OTHER NON CURRENT LIABILITIES	
Payable under Special Instalment Programme #	55.422
Other Taxes Payables	43.229
	98.651

Payable to the State Government of Sao Paulo, Brazil in 73 unequal instalments at the interest rate of 1% per month.

NOTES TO CONSOLIDATED FINANCIAL STATEMENTS (Contd.,)

31-3-2017
₹ Million

2.7. SHORT TERM BORROWINGS

Secured Loans

Working Capital Facilities from Banks

- In Rupee	566.808
- In Foreign Currency	175.158

Unsecured Loans

Working Capital Facilities from Banks

- In Rupee	200.000
	<u>941.966</u>

Working capital facilities from banks are secured by pari-passu first charge on the current assets of the respective companies. The loans are further secured by second pari-passu charge on the specific immovable properties of the respective Companies. The loans are further Guaranteed by the holding company.

Working Capital Facilities from Bank of Bahrain and Kuwait B.S.C. is secured by an exclusive charge on the specific land and building of Plant III situated at Billichchi Village, Coimbatore District.

Working Capital Facilities from Banks are repayable on demand and carry interest rates varying from 7.50% to 11.10% p.a.

2.8. TRADE PAYABLES

Trade Creditors	2,410.180
	<u>2,410.180</u>

2.9. OTHER CURRENT LIABILITIES

Current Maturities of Long Term Debt (Refer to Note No. 2.3)	455.887
Interest Accrued and not due on borrowings	5.037
Unclaimed Dividend	7.123
Statutory Dues Payable	132.406
Employee Benefit Expense Payable	462.765
Other Payables *	246.549
	<u>1,309.767</u>

* Other Payables includes accrued expenses and Rental Deposit Received

2.10. SHORT TERM PROVISIONS

For Employee Benefits :

- Gratuity	15.004
For Labour Settlement (Refer to Note No. 2.40)	26.172
For Taxation (Net)	20.009
	<u>61.185</u>

2.11. FIXED ASSETS

₹ Million

	Gross Block				Depreciation / Amortisation				Net Block				
	Cost as on 1-4-2016	Additions during 2016-17	Assets acquired on Amalgamation (Net) #	Sales / Deletions during 2016-17	Translation Adjustment	Balance as on 31-3-2017	Upto 31-3-2016	For 2016-17	Adjustments on Amalgamation (Net) #	Withdrawn during 2016-17	Translation Adjustment	Total upto 31-3-2017	Written down Value as on 31-3-2017
Property, Plant and Equipment													
Land :													
Freehold Land	195.064	—	980.220	2.322	2.200	1,174.671	—	—	—	—	—	—	1,174.671
Leasehold Land	—	—	76.100	—	—	76.100	—	0.789	0.271	—	—	1.060	75.040
Buildings :													
Freehold Buildings	165.959	60.455	1,356.864	2.030	0.193	1,581.804	21.755	80.507	113.744	0.014	(1.477)	214.515	1,367.289
Leasehold Buildings	—	24.870	9.794	—	0.783	35.447	—	1.730	7.160	—	0.585	9.475	25.972
Plant & Machinery	183.022	545.475	1,936.732	245.732	38.460	3,012.044	82.171	288.608	1,058.450	13.171	68.036	1,484.094	1,527.950
Furniture and Fixtures	1.791	29.053	38.110	2.399	1.536	71.151	0.635	5.546	12.966	0.440	0.892	19.599	51.552
Vehicles	1.033	2.116	12.582	12.388	0.143	28.103	0.066	3.975	2.381	0.111	0.032	6.343	21.760
Office Equipments	2.937	1.650	44.708	0.002	2.778	47.994	0.830	4.162	39.397	0.133	(1.638)	42.618	5.376
Computer Equipments	1.160	56.573	110.571	33.276	0.517	201.026	1.103	34.390	35.137	0.345	(0.037)	70.248	130.778
Total Property, Plant and Equipment	550.966	720.192	4,565.681	298.149	45.827	6,228.340	106.560	419.707	1,269.506	14.214	66.393	1,847.952	4,380.388
Intangible Assets													
Computer Software	0.683	22.298	89.430	11.188	0.038	125.755	0.603	29.080	46.120	0.036	1.506	77.273	48.482
Technical Knowhow	—	—	2.775	48.307	—	51.082	—	1.022	48.845	—	—	49.867	1.215
Brand / Trade Mark	—	—	508.957	—	—	511.342	—	33.701	39.539	—	0.735	73.975	437.367
Patents & Developed Technology	—	—	1,411.600	—	—	1,411.600	—	94.107	94.107	—	—	188.214	1,223.386
Goodwill \$	300.845	—	1,490.100	—	—	1,790.945	242.978	157.207	99.340	—	—	499.525	1,291.420
Total Intangible Assets	301.528	22.298	3,502.862	59.495	0.038	3,890.724	243.581	315.117	327.951	0.036	2.241	888.854	3,001.870
Total	852.494	742.490	8,068.543	357.644	45.865	10,119.064	350.141	734.824	1,597.457	14.250	68.634	2,736.806	7,382.256
Capital Work-in-progress													
													266.528

Note : # Adjustments on Amalgamation represents changes in Gross Block / Accumulated depreciation in books of Erstwhile Pricol Limited post the appointed date. (Refer to Note No. 2.32)
 \$ Additions to Goodwill represents Customer Relationships and Assembled Workforce acquired consequent to Amalgamation. (Refer to Note No. 2.32)
 Adjustment on account of foreign exchange translation difference on opening balance and depreciation charge for the year is reflected as "Translation Adjustment".

NOTES TO CONSOLIDATED FINANCIAL STATEMENTS (Contd.,)

31-3-2017
₹ Million

2.12. LONG TERM LOANS AND ADVANCES

Unsecured Considered Good

Capital Advances		165.451
Deposits with Custom Authorities		7.399
Other Deposits #		49.341

Unsecured Considered Doubtful

Other Deposits #	2.610	
Less : Provision for Doubtful Deposits	2.610	—
		<u>222.191</u>

Other Deposits includes Rental & Security Deposits

2.13. OTHER NON-CURRENT ASSETS

Unsecured Considered Good

Loans to Employees		0.046
Balances with Government Authorities		6.443
Advance Tax, Net off Provision		100.336
MAT Credit Entitlement		374.666
		<u>481.491</u>

2.14. CURRENT INVESTMENTS

S. No.	Particulars	Amount (₹ Million) 31-3-2017	Market Value (₹ Million) 31-3-2017
Investment in Mutual Funds - Non Trade - Quoted - Fully paid - Valued at Lower of Cost and Net Realisable Value			
1.	ICICI Prudential MIP - 25 - Growth - Regular Plan	0.700	0.836
2.	IDFC Asset Allocation Fund of Funds - Aggressive Plan - Growth - Regular Plan	0.700	0.807
3.	Birla Sun Life MIP II - Wealth 25 Plan - Growth - Regular Plan	0.700	0.865
Aggregate Cost / Market Value of Quoted Investments		<u>2.100</u>	<u>2.508</u>

2.15. INVENTORIES

(Valued at Lower of Cost and Net Realisable Value)

Raw Materials & Components (includes Goods in Transit of ₹ 130.865 Million)	965.282
Work-in-progress	123.890
Finished Goods	407.470
Land - Stock-in-Trade	141.900
Stores & Spares	63.208
Traded Goods	27.687
	<u>1,729.437</u>

NOTES TO CONSOLIDATED FINANCIAL STATEMENTS (Contd.,)

		31-3-2017
		₹ Million
2.16. TRADE RECEIVABLES		
a) Outstanding for a period exceeding six months from the date they are due for payment		—
i) Unsecured Considered Good		—
ii) Unsecured Considered Doubtful	101.490	
Less : Provision for Doubtful Debts	101.490	—
b) Outstanding for a period less than six months from the date they are due for payment		
i) Unsecured Considered Good		2,111.825
ii) Unsecured Considered Doubtful	1.439	
Less : Provision for Doubtful Debts	1.439	—
		<u>2,111.825</u>
2.17. CASH AND CASH EQUIVALENTS		
Balances with Banks		
In Current Account	56.938	
In Unclaimed Dividend Account	7.123	
In Fixed Deposit Account	201.459	
In Margin Money Account #	11.961	
Cash on hand	1.552	279.033
		<u>279.033</u>
# Margin Money with banks is towards issue of Letter of Comfort, Letter of Credit, Buyers Credit for Imports and Bank Guarantee.		
Of the above, the balances that meet the definition of Cash and Cash equivalent as per AS 3 Cash Flow Statement is		<u>58.490</u>
2.18. SHORT TERM LOANS AND ADVANCES		
Unsecured Considered Good		
Advances to Employees		11.863
Advances to Suppliers #		143.063
Balances with Government Authorities		248.490
Unsecured Considered Doubtful		
Advances to Suppliers #	1.133	
Less : Provision for Doubtful Advances	1.133	—
		<u>403.416</u>
2.19. OTHER CURRENT ASSETS		
Unsecured Considered Good		
Accrued Income		3.284
Prepaid Expenses		33.645
		<u>36.929</u>

NOTES TO CONSOLIDATED FINANCIAL STATEMENTS (Contd.,)

		2016-17 ₹ Million
2.20. REVENUE FROM OPERATIONS		
Sale of Products and Services		
Domestic	14,142.040	
Export	1,231.474	
Traded Goods	104.695	
Service Income	40.659	
	<u>15,518.868</u>	
Less : Excise Duty	1,288.467	<u>14,230.401</u>
2.21. OTHER OPERATING REVENUE		
Export Incentives		10.253
Sale of Traded Goods - Others		<u>491.715</u>
		<u>501.968</u>
2.22. OTHER INCOME		
Interest Received		10.553
Income from Current Investments		0.482
Rent Received		21.694
Profit on Sale of Assets (Net)		3.772
Miscellaneous Income		14.470
Excess Provision No Longer Required Written Back		20.871
Provision for Diminution in Value of Current Investments Written Back		0.370
Gain on Exchange Fluctuation (Net)		<u>11.162</u>
		<u>83.374</u>
2.23. COST OF MATERIALS CONSUMED		
Materials Consumed		<u>9,096.811</u>
2.24. CHANGES IN INVENTORIES OF WORK-IN-PROGRESS, FINISHED GOODS AND STOCK-IN-TRADE		
Opening Stock		
Work-in-progress	9.772	
Finished Goods	3.216	
Traded Goods	—	
Land - Stock-in-Trade	—	<u>12.988</u>
Add: Inventory Acquired on Amalgamation		
Work-in-progress	109.354	
Finished Goods	161.684	
Traded Goods	29.118	
Land - Stock-in-Trade	141.900	<u>442.056</u>
Less : Closing Stock		
Work-in-progress	123.890	
Finished Goods	407.470	
Traded Goods	27.687	
Land - Stock-in-Trade	141.900	<u>700.947</u>
		<u>(245.903)</u>

NOTES TO CONSOLIDATED FINANCIAL STATEMENTS (Contd.,)

	2016-17
	₹ Million
2.25. EMPLOYEE BENEFITS EXPENSE	
a) Pay, Allowances and Bonus	2,170.664
b) Contribution to Provident and other funds	109.926
c) Welfare Expenses	136.098
	<u>2,416.688</u>
2.26. FINANCE COSTS	
Interest On Loans	169.414
Other Borrowing Costs	2.105
Exchange differences to the Extent considered as an adjustment to borrowing cost	5.029
	<u>176.548</u>
2.27. DEPRECIATION & AMORTISATION EXPENSE	
Depreciation (Refer to Note No. 2.11)	419.707
Amortisation (Refer to Note No. 2.11)	315.117
	<u>734.824</u>
2.28. OTHER EXPENSES	
Power & Utilities	241.877
Stores & Spares Consumed	48.241
Repairs and Maintenance :	
- Machinery	144.995
- Building	58.848
- Others	85.811
Printing & Stationery	13.566
Postage & Telephone	24.666
Rent	77.950
Rates, Taxes & Licence	39.081
Insurance	31.230
Bank Charges	9.776
Travelling & Conveyance	140.190
Freight & Forwarding and Selling Expenses	294.256
Advertisement & Sales Promotion	19.831
Commission & Discount on Sales	39.822
Royalty	7.284
Bad Debts Written off	1.679
Provision for doubtful debts & advances	11.574
Less : Provision for doubtful debts & advances written back	<u>2.243</u>
	9.331
Commission / Sitting Fees to Non-Whole Time Directors	3.494
Auditors' Remuneration (Refer to Note No. 2.35)	8.305
Professional Charges	456.737
Assets Discarded / Written off	13.564
Miscellaneous Expenses	69.901
CSR Expenses	3.950
Donations	3.015
	<u>1,847.400</u>

NOTES TO CONSOLIDATED FINANCIAL STATEMENTS (Contd.,)

2016-17
₹ Million

2.29. EXCEPTIONAL ITEMS

Profit on Sale of Investment - Wholly owned subsidiary M/s. Integral Investments Limited #	10.500
	<u>10.500</u>

On 15th June, 2016 the Company sold its 100% shareholding in its wholly owned subsidiary company, M/s. Integral Investments Limited for a consideration of ₹ 27.837 Million.

2.30. EARNINGS PER SHARE

Profit After Tax	73.853
Weighted Average No. of Shares Outstanding :	
Basic & Diluted (Nos. in Mn.)	94.797
Basic & Diluted Earnings per share (in ₹)	0.78
Face Value per Equity Share (in ₹)	1.00

2.31. SUBSIDIARY COMPANIES CONSIDERED IN THE CONSOLIDATED FINANCIAL STATEMENTS :

S. No.	Name of the Company	Country of Incorporation	Relationship	% of Ownership
1.	Integral Investments Limited	India	Subsidiary	100%
			Upto 15th June, 2016	
2.	PT Pricol Surya Indonesia	Indonesia	Subsidiary	100%
3.	Pricol Asia Pte. Limited	Singapore	Subsidiary	100%
4.	Pricol Espana S.L.	Spain	Subsidiary	100%
5.	Pricol do Brasil Componentes Automotivos Ltda	Brazil	Subsidiary of Pricol Espana S.L.	100%

2.32. AMALGAMATION OF ERSTWHILE PRICOL LIMITED WITH THE COMPANY :

- (a) The shareholders of Erstwhile Pricol Limited (Transferor Company) and Erstwhile Pricol Pune Limited (Transferee Company) approved the Scheme of Amalgamation ("Scheme") of Transferor Company with the appointed date as 1st April, 2015. Pricol Limited was engaged in the manufacturing, marketing, trading and export of Automotive Components and precision engineered products to Original Equipment Manufacturers and Replacement Market. The said scheme was as sanctioned by the Hon'ble High Court of Judicature at Madras on 6th October, 2016. The certified copy of the High Court sanctioning the Scheme was filed with Ministry of Corporate Affairs on 1st November, 2016 (Effective Date). The scheme has accordingly been given effect to in the financial statements. The amalgamation has been accounted for under the "Purchase Method" as prescribed under Accounting Standard 14 - "Accounting for Amalgamations" (AS 14) notified under the Companies Act 2013. Accordingly, giving effect to the Scheme of Amalgamation, all the assets (including intangible assets if any whether or not recorded in the books of Transferor Company) and liabilities of Transferor Company were recorded in the books of the Transferee Company at their respective fair values. In respect of Inter-company owings, the outstanding balance (Net) of ₹ 50.390 Million have been eliminated. Pursuant to the Scheme of Amalgamation, the Transferee Company was renamed as "Pricol Limited" vide fresh Certificate of Incorporation granted by the Ministry of Corporate Affairs on 18th November, 2016.
- (b) Upon the Scheme being effective, in consideration of the transfer and vesting of the entire undertaking of the business of the Transferor Company, the shareholders of the Transferor Company as on the Record date (6th December, 2016) have been allotted one equity share of ₹ 1 each fully paid-up of Transferee Company for every one equity share of ₹ 1 each fully paid-up in the Transferor Company. Thus, the Transferee Company has allotted 94,796,721 Equity Share of ₹ 1 each fully paid-up and the Transferee Company has accounted for Securities Premium of ₹ 7,412.156 Million representing a premium of ₹ 78.19 per equity share. The shares held by the Transferor Company in Transferee Company stands cancelled pursuant to Scheme of Amalgamation.

NOTES TO CONSOLIDATED FINANCIAL STATEMENTS (Contd.,)

AMALGAMATION OF ERSTWHILE PRICOL LIMITED WITH THE COMPANY (Contd.,)

- (c) Intangible Assets acquired by the Transferee Company pursuant to amalgamation include :
- (i) separately identified intangible assets like Brand / Trade Mark, Patents & Developed Technology
 - (ii) Goodwill comprising other intangible assets namely Customer Relationships and Assembled Workforce, in line with Accounting Standard - 26 (AS 26) on "Intangible Assets". Such Goodwill has been treated at par with other separately identified intangible assets and is amortised over a period of 15 years. Para 19 of AS-14 considers a period of 5 years as appropriate to amortise the goodwill on amalgamation unless a longer period is justified. The company has made a technical evaluation on the useful life, which has been relied upon by the auditors, based on which the goodwill has been amortised over a period of 15 years.

Disclosure of impact on adopting a longer useful life in the financial statements :

The amortisation expense for the year would have been higher by ₹ 198.680 Million, the profit for the year would have been lower by ₹ 198.680 Million, adjustment pursuant to Scheme of Amalgamation in the opening balance of Deficit in the Statement of Profit and Loss higher by ₹ 198.680 Million and the resultant Reserves and Surplus lower by ₹ 397.360 Million.

- (d) The working results of the transferor company for the period 1st April, 2015 to 31st March, 2016 has been adjusted in the opening balance of Surplus / (Deficit) in Statement of Profit and Loss.

2.33. Based on the Transitional Provisions contained in Para 30 of Accounting Standard (AS) - 21 "Consolidated Financial Statements", the comparative figures for the previous year ended 31st March 2016 have not been presented in the consolidated financial statements.

2.34. The Component auditor of Pricol do Brasil Componentes Automotivos Ltda. has given a modified opinion in their audit report stating that the component has recorded deferred tax assets from tax losses and other temporary differences which does not meet the criteria defined for recognition of deferred tax asset as per Brazilian generally accepted accounting principles resulting in the non current assets and reserves being overstated by BRL 6,161 (Brazilian Reals in thousands). Necessary adjustments have been made in the previous year consolidated financial statements of Erstwhile Pricol Limited to derecognise the Deferred Tax Asset and hence no further adjustments is required in the consolidated financial statements.

2.35. REMUNERATION TO AUDITORS (EXCLUSIVE OF SERVICE TAX) :

For Audit	6.225
For Taxation Matters	0.942
For Certification and Others	0.959
Reimbursement of Expenses	0.179
	8.305

2.36. CONTINGENT LIABILITIES AS ON THE CLOSING DATE :

CONTINGENT LIABILITIES

- in respect of Holding Company

a) On account of Pending Litigations

Sales Tax Matters (excluding Interest if any)	51.073
Excise, Service Tax and Customs Matters (excluding Interest & Penalty if any)	225.633

b) Others

Letter of Credit	133.456
	410.162

NOTES TO CONSOLIDATED FINANCIAL STATEMENTS (Contd.,)

2016-17
₹ Million

2.37. The Company's operations mainly relate to one segment, Automotive Components. The Secondary segment disclosure in respect of the identified geographical segments is given below :

1. Segment Revenue	
Within India	11,807.634
Outside India	2,924.735
Unallocated	83.374
	<u>14,815.743</u>
2. Segment Expenses	
Within India	9,092.266
Outside India	2,674.284
	<u>11,766.550</u>
3. Segment Results	
Within India	2,715.368
Outside India	250.452
	<u>2,965.820</u>
Less : Depreciation and Amortisation Expense - Unallocated portion	417.562
Less : Unallocated (Income) / Expenses	2,301.260
Profit from operations before Exceptional Items and Tax	246.998
Add : Exceptional Items (Refer to Note No. 2.29)	10.500
Less : Tax Expense	183.645
Profit After Tax	<u>73.853</u>
4. Segment Assets	
Within India	4,805.006
Outside India	1,729.367
Unallocated	6,380.835
	<u>12,915.208</u>
5. Segment Liabilities	
Within India	2,093.509
Outside India	1,276.928
Unallocated	2,318.180
	<u>5,688.617</u>
6. Capital Expenditure	
Within India	561.516
Outside India	23.392
Unallocated	310.389
	<u>895.297</u>
7. Depreciation & Amortisation	
Within India	252.153
Outside India	65.109
Unallocated	417.562
	<u>734.824</u>

NOTES TO CONSOLIDATED FINANCIAL STATEMENTS (Contd.,)

2016-17
₹ Million

2.38. Additional information pursuant to para 2 of general instructions for the preparation of consolidated financial statements :

S. No.	Name of the Entity	Net Assets		Share in Profit or (Loss)	
		As a % of Consolidated Net Assets	Amount ₹ Million	As a % of Consolidated Profit or (Loss)	Amount ₹ Million
Parent					
1.	Pricol Limited	98.87%	7,145.106	626.18%	462.449
Subsidiaries					
1.	PT Pricol Surya Indonesia	3.80%	274.860	12.60%	9.305
2.	Pricol Asia Pte Limited, Singapore	0.93%	67.340	55.17%	40.747
3.	Pricol Espana S.L., Spain	0.04%	2.641	(11.73)%	(8.665)
4.	Pricol do Brasil Componentes Automotivos Ltda. Brazil	(3.64)%	(263.356)	(582.92)%	(430.502)
5.	Integral Investments Limited	—	—	0.70%	0.519
Total		100.00%	7,226.591	100.00%	73.853

2.39. a) Particulars regarding defined benefit plan :

The company operates a defined benefit plan for payment of post employment benefits in the form of Gratuity. Benefits under the plan are based on pay and years of service and are vested on completion of five years of service, as provided in the Payment of Gratuity Act, 1972. The terms of the benefits are common for all the employees of the Company.

I. Principal actuarial assumptions used as at the Balance Sheet Date :

Period Covered	2016-17
Discount Rate	7.13% p.a.
Expected Return on Plan assets	7.50% p.a.
Average future working life	15 yrs
The estimates of future salary increases are considered in actuarial valuation, taking into account of inflation, seniority, promotion and other relevant factors such as supply and demand in the employment market.	

II. Changes in the Present Value of the Obligation :

	₹ Million
Present Value of obligation at the beginning of the period (including adjustment on Amalgamation)	293.979
Interest cost	19.509
Current service cost	18.262
Past service cost	—
Benefits paid	(34.008)
Transfer of obligation due to Transfer of Employees to Group Entities	(6.708)
Actuarial (Gain) / Loss on obligation	19.667
Present Value of obligation at the end of the period	310.701

NOTES TO CONSOLIDATED FINANCIAL STATEMENTS (Contd.,)

2016-17
₹ Million

III. Changes in the Fair Value of plan assets :

Fair Value of plan assets at the beginning of the period (including adjustment on Amalgamation)	172.407
Expected return on plan assets	16.752
Contributions	122.600
Benefits paid	(31.924)
Transfer of obligation due to Transfer of Employees to Group Entities	(6.708)
Actuarial Gain / (Loss) on plan assets	1.186
Fair Value of plan assets as at the end of the period	274.313

IV. Amounts recognised in the Balance Sheet :

Present Value of obligation	310.701
Fair Value of plan assets	(274.313)
Liability / (Asset)	36.388
Unrecognised past service cost	—
Asset / (Liability) recognised in the Balance Sheet	(36.388)

V. Expenses recognised in the Statement of Profit & Loss :

Current service cost	18.262
Interest Cost	19.509
Expected return on plan assets	(16.752)
Net Actuarial (Gain) / Loss recognised in the year	18.481
Past service cost	—
Expenses recognised in the Statement of Profit & Loss	39.500

The expense has been included under the head "Contribution to provident and other funds" under "Employee Benefits Expense" in the Statement of Profit and Loss.

₹ Million

	2016-17	2015-16	2014-15	2013-14	2012-13
VI. Amount for the current period :					
Present Value of obligation	310.701	1.813	3.097	2.370	2.930
Plan Assets	274.313	2.436	3.069	3.200	2.390
Surplus / (Deficit)	(36.388)	0.623	(0.028)	0.830	(0.540)
Experience adjustments on plan liabilities	(31.422)	(0.817)	0.190	(0.190)	—
Experience adjustments on plan assets	0.069	(0.034)	0.010	0.030	0.110

VII. Major Categories of plan assets (As percentage of total plan assets)

2016-17

Funds Managed by Insurance Companies 100%

VIII. Enterprise's best estimate of contribution during next year (₹ Million.)

15.004

b) Contribution of ₹ 65.400 Million (Previous year - ₹ 1.986 Million) made to defined contribution plans were charged to Consolidated Statement of Profit and Loss.

NOTES TO CONSOLIDATED FINANCIAL STATEMENTS (Contd.,)**2.40. PROVISIONS AS ON THE CLOSING DATE :**

₹ Million

	Opening Balance 1-4-2016	Addition / Adjustment on Amalgamation	Utilised / Reversed	Closing Balance 31-3-2017
Long Term Provisions :				
Excise Demands	—	69.158	—	69.158
Potential Statutory Liabilities	—	57.182	2.346	54.836
Labour Related Claims	—	30.619	—	30.619
Total Long Term Provisions	—	156.959	2.346	154.613
Short Term Provisions :				
Labour Settlement	—	27.502	1.330	26.172
Total Provisions	—	184.461	3.676	180.785

2.41. The audited Financial Statements of Foreign Subsidiaries have been prepared in accordance with the generally accepted accounting principles prevailing in its country of incorporation.

2.42. OTHER NOTES FORMING PART OF ACCOUNTS :

These are set out in and under "Notes to Financial Statement forming part of accounts for the year ended 31st March 2017" as given in the standalone financial statements of Pricol Limited.

2.43. DETAILS OF SPECIFIED BANK NOTES (SBN) :

₹ Million

Particulars	Details of SBN	Other than SBN	Total
Closing Cash in hand as on 8th November, 2016	2.192	0.582	2.774
Transactions between 9th November, 2016 and 30th December, 2016			
Add : Permitted Receipts	20.010	20.800	40.810
Less : Permitted Payments	—	2.409	2.409
Less : Amount Deposited in Banks	22.202	17.210	39.412
Closing Cash in hand as on 30th December, 2016	—	1.763	1.763

2.44. All figures are in Million unless otherwise stated.

2.45. RELATED PARTY TRANSACTIONS AS PER ACCOUNTING STANDARD 18 :

Related parties where significant influence exists and with whom transactions have taken place during the year :

- Partnership firms under common control :** Bhavani Global Enterprises, Ellargi & Co, Libra Industries.
- Public Limited Companies :** Pricol Holdings Limited, PPL Enterprises Limited, Pricol Properties Limited, Pricol Technologies Limited, Pricol Travel Limited, Pricol Engineering Industries Limited, Pricol Corporate Services Limited, Printra Limited, Target Manpower Services Limited.
- Key Management Personnel :** Mrs. Vanitha Mohan, Mr. Vikram Mohan
- Relatives of Key Management Personnel :** Mr. Vijay Mohan

NOTES TO CONSOLIDATED FINANCIAL STATEMENTS (Contd.,)**(ii) Related party transactions**

Particulars	2016-17 ₹ Million
Transactions during the year	
Purchase / Labour Charges	
Ellargi & Co	0.155
Libra Industries	185.982
PPL Enterprises Limited	63.443
Pricol Technologies Limited	0.096
Pricol Engineering Industries Limited	0.780
Sales / Job Work Charges	
Libra Industries	1.789
PPL Enterprises Limited	0.663
Pricol Technologies Limited	0.003
Pricol Engineering Industries Limited	0.339
Receiving of Services / Reimbursement of Expenses Paid	
PPL Enterprises Limited	1.225
Pricol Technologies Limited	115.091
Pricol Travel Limited	369.681
Pricol Corporate Services Limited	220.374
Target Manpower Services Limited	25.609
Mr. Vijay Mohan	0.500
Mrs. Vanitha Mohan	16.770
Mr. Vikram Mohan	29.648
Rendering of Services / Reimbursement of Expenses Received	
Bhavani Global Enterprises	5.248
Pricol Holdings Limited	0.060
PPL Enterprises Limited	0.045
Pricol Technologies Limited	5.190

Related party transactions (Contd.,)

Particulars	2016-17 ₹ Million
Pricol Travel Limited	0.078
Pricol Engineering Industries Limited	13.435
Pricol Corporate Services Limited	0.599
Target Manpower Services Limited	0.016
Loans and advances given / (repaid)	
Pricol Properties Limited	3.337
Pricol Travel Limited	0.058
Pricol Technologies Limited	(0.685)
Amount outstanding as at the balance sheet date :	
Trade and Other Receivables	
Bhavani Global Enterprises	0.422
Libra Industries	0.446
PPL Enterprises Limited	0.056
Pricol Technologies Limited	0.054
Pricol Engineering Industries Limited	2.927
Ellargi & Co.	0.007
Pricol Corporate Services Limited	0.051
Pricol Properties Limited	69.849
Trade Payables and Other Payables	
Libra Industries	29.446
PPL Enterprises Limited	6.673
Pricol Technologies Limited	25.050
Pricol Travel Limited	33.563
Target Manpower Services Limited	3.435
Mrs. Vanitha Mohan	10.086
Mr. Vikram Mohan	13.448

As per our report of even date attached
For Haribhakti & Co. LLP
Chartered Accountants
ICAI Firm Regn. No. 103523W/W100048
Kaushik Sidartha
Partner
Membership No. 217964
Coimbatore, 30th May 2017

Vijay Mohan
Chairman
(DIN : 00001843)

S. Shrinivasan
Chief Financial Officer
(ACMA No. : 17505)

For and on behalf of the Board
Vanitha Mohan
Vice Chairman
(DIN : 00002168)

Vikram Mohan
Managing Director
(DIN : 00089968)

T. G. Thamizhanban
Company Secretary
(FCS No. 7897)

Statement containing salient features of the financial statement of subsidiaries / associate companies / joint ventures

Part - "A" - Subsidiaries

₹ Million

Particulars	PT Pricol Surya Indonesia	Pricol Asia Pte. Limited, Singapore	Pricol Espana S.L. Spain	Pricol do Brasil Componentes Automotivos Ltda Brazil (Subsidiary of Pricol Espana)	Integral Investments Limited #
Reporting Period	Apr - Mar	Apr - Mar	Apr - Mar	Apr - Mar	Apr - Mar
Reporting Currency	Indonesian Rupiah (IDR)	US Dollar (USD)	Euro (EUR)	Brazilian Reals (BRL)	Indian Rupee (INR)
Exchange Rate for 1 reporting currency as on 31st March, 2017 (INR)	0.00487	64.903	69.687	20.773	N.A.
Share Capital	435.226	16.226	619.155	2,068.807	22.500
Reserves and Surplus	(209.155)	88.363	(10.904)	(2,215.423)	4.839
Total Assets	627.906	335.822	617.600	959.901	27.382
Total Liabilities	627.906	335.822	617.600	959.901	27.382
Investments	—	—	604.105	—	—
Turnover	922.378	1,500.798	1.069	1,233.804	0.167
Profit / (Loss) before Tax	9.829	58.063	(8.665)	(432.067)	0.501
Provision for Taxation	0.025	8.052	—	3.587	(0.018)
Profit / (Loss) after Tax	9.804	50.011	(8.665)	(435.654)	0.519
Proposed Dividend	—	—	—	—	—
% of Shareholding	100%	100%	100%	100%	100%

Disposed off in current year.

Part - "B" - Associates and Joint Ventures

Not Applicable

		For and on behalf of the Board	
	Vijay Mohan Chairman (DIN : 00001843)	Vanitha Mohan Vice Chairman (DIN : 00002168)	Vikram Mohan Managing Director (DIN : 00089968)
Coimbatore 30th May 2017	S. Shrinivasan Chief Financial Officer (ACMA No. : 17505)		T. G. Thamizhanban Company Secretary (FCS No. 7897)

Notes

A series of horizontal dotted lines for writing notes.



PRICOL LIMITED

109 Race Course, Coimbatore - 641 018, Tamilnadu, India.
Phone : +91 422 433 6000 Fax : +91 422 433 6299
Email : cs@pricol.co.in, Website: www.pricol.com
CIN:L34200TZ2011PLCO22194